

Low pressure gauge (Capsule system)

Model : P422 series

Spec. sheet no. PD04-03

Service intended

P422 series are designed to measure low, vacuum or compound pressure. These models have a 316L SS measuring element which consists of two formed diaphragms and diaphragms are welded together.



Nominal diameter

63, 80, 100 and 160 mm

Accuracy

±1.0 % of full scale

±1.6 % of full scale

Scale range (kPa, mbar)

-35 ~ 0 to -1 ~ 0 kPa

-15 ~ 15 to -0.5 ~ 0.5 kPa

0 ~ 1 to 0 ~ 35 kPa

Working pressure

Steady : 75 % of full scale

Over range protection : 130% of full scale

Working temperature

Ambient : -20 ~ 65 °C

-40 ~ 65 °C (With silicone filling)

Fluid : Max. 100 °C

Temperature effect

Accuracy at temperature above and below the reference temperature (20 °C) will be effected by approximately ±0.6 % per 10 °C of full scale



Standard features

Pressure connection

Stainless steel (316SS)

Element

Stainless steel (316L SS)

Capsule system : Up to 35 kPa

Case

Stainless steel (304SS)

Cover

Stainless steel (304SS)

Window

Safety glass

Movement

Stainless steel

Dial

White aluminium with black graduations

Pointer

Black painted aluminium alloy

Process connection

1/4", 3/8", 1/2" PT, NPT and PF

Certificates

ATEX Ex II GD c IIc TX

Option

Silicone filling

WISE[®]

| P422_01

1. Base model**P422** Low pressure gauge (Capsule system)**2. Nominal diameter (mm)**

- 2 63
- 3 80
- 4 100
- 6 160

3. Type of mounting

- A Bottom connection, direct, not available with diameter 63 mm
- B Bottom connection, surface, case mounting plate, not available with diameter 63 mm
- F Center back connection, direct, only available with diameter 63 mm

4. Accuracy

- 3 ±1.0 % of full scale, not available with diameter 63 and 80 mm
- 4 ±1.6 % of full scale

5. Process connection

- B 1/8"
- C 1/4"
- D 3/8", not available with diameter 63 mm
- E 1/2", not available with diameter 63 and 80 mm

6. Connection type

- B PF
- C PT
- D NPT
- Z Other

7. Unit

- J kPa
- S mbar

8. Range

XXX Refer to pressure un

405 : -50~0 mbar**9. Pressure connection material and dial color**

- 3 316SS and 2 colors
- 4 316L SS and 2 colors
- 7 316SS and 3 colors
- 8 316L SS and 3 colors
- Z Monel

10. Option

- 0 None
- 1 Accessories
- 2 Silicone filling

1	2	3	4	5	6	7	8	9	10
P422	4	A	3	E	C	J	XXX	3	0

Sample
ordering code

P422 : Type of mounting

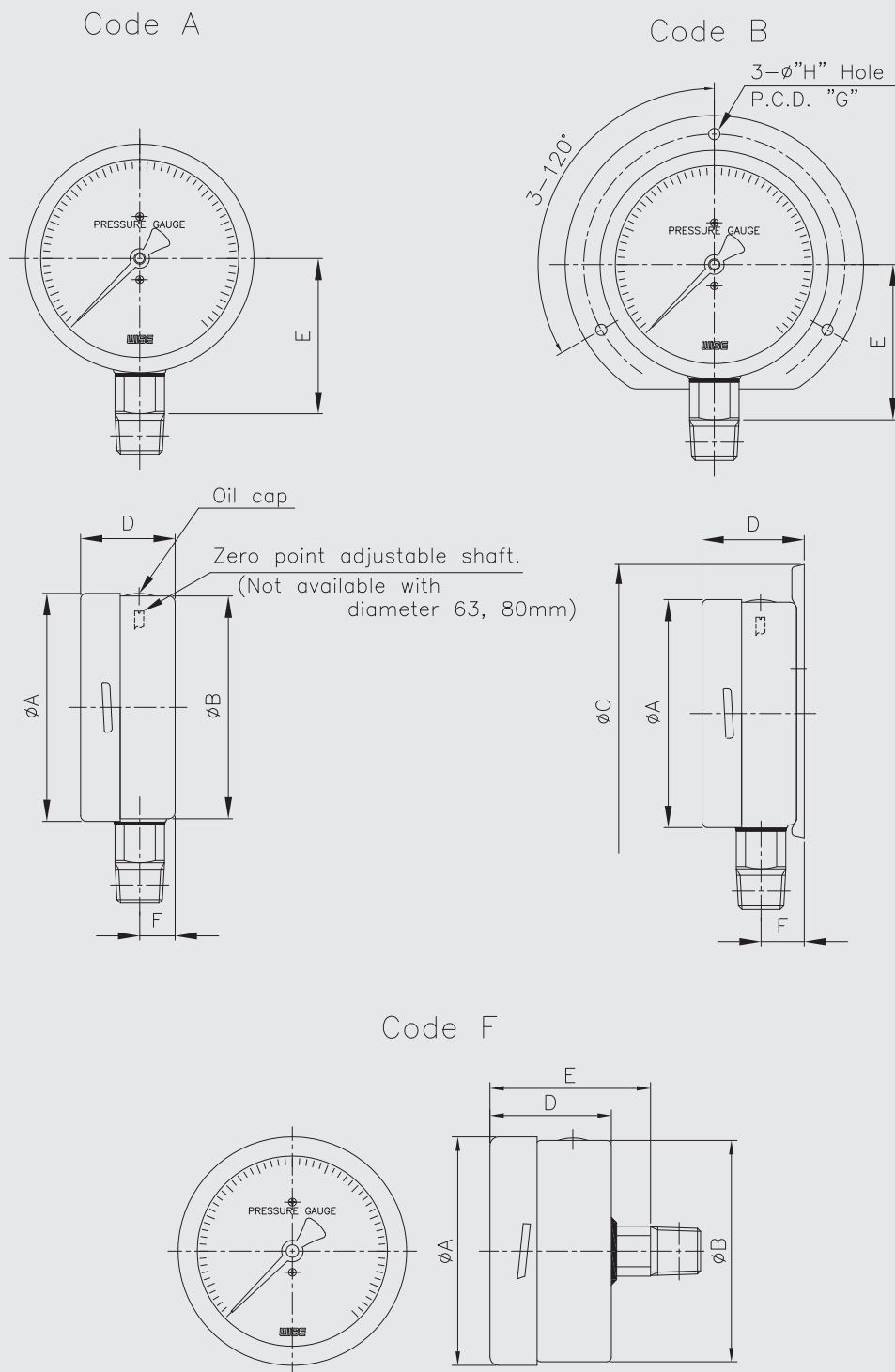

Dimensions (mm)

Dial size	Available code	A	B	C	D \pm 2	E \pm 2	F \pm 1	G	H
63	F	64	62		34	45			
80	A	81.2	78.5		44.5	50.5	12		
	B	81.2		108	48	50.5	15.5	95	5
100	A	101.3	99		50	73.5	16		
	B	101.3		133	54.4	73.5	19.4	116	5
160	A	160.6	159		52.5	105.5	15.8		
	B	160.6		196	56	105.5	19.4	178	5.8

Pressure unit and range table

Range and code	Unit and code		Nominal diameter			
	S : mbar	J : kPa	63 mm	80 mm	100 mm	160 mm
503	-350 ~ 0	-35 ~ 0	○	○	○	○
400	-300 ~ 0	-30 ~ 0	○	○	○	○
502	-250 ~ 0	-25 ~ 0	○	○	○	○
401	-200 ~ 0	-20 ~ 0	○	○	○	○
402	-150 ~ 0	-15 ~ 0	○	○	○	○
403	-100 ~ 0	-10 ~ 0	○	○	○	○
405	-50 ~ 0	-5 ~ 0	○	○	○	○
406	-40 ~ 0	-4 ~ 0	○	○	○	○
407	-30 ~ 0	-3 ~ 0	○	○	○	○
408	-20 ~ 0	-2 ~ 0	○	○	○	○
472	-150 ~ 150	-15 ~ 15	○	○	○	○
470	-100 ~ 100	-10 ~ 10	○	○	○	○
413	-50 ~ 50	-5 ~ 5	○	○	○	○
415	-40 ~ 40	-4 ~ 4	○	○	○	○
417	-30 ~ 30	-3 ~ 3	○	○	○	○
418	-25 ~ 25	-2.5 ~ 2.5	○	○	○	○
419	-20 ~ 20	-2 ~ 2	○	○	○	○
421	-10 ~ 10	-1 ~ 1	○	○	○	○
460	0 ~ 20	0 ~ 2	○	○	○	○
462	0 ~ 30	0 ~ 3	○	○	○	○
464	0 ~ 40	0 ~ 4	○	○	○	○
465	0 ~ 50	0 ~ 5	○	○	○	○
469	0 ~ 100	0 ~ 10	○	○	○	○
515	0 ~ 150	0 ~ 15	○	○	○	○
437	0 ~ 200	0 ~ 20	○	○	○	○
517	0 ~ 250	0 ~ 25	○	○	○	○
518	0 ~ 300	0 ~ 30	○	○	○	○
519	0 ~ 350	0 ~ 35	○	○	○	○

○ : Available X : Not available