

SOHO NC SENSORLESS VECTOR INVERTER

Warning

1. Please read the manual before using the SOHO NC Inverter for the safety.
2. Experts at the electric construction and wiring work must handle for the safety.

SEOHO DRIVES, LTD.
www.seoho.com

Tel) +82-31-463-6710~13 (Sales Part)
+82-31-463-6720~23 (Customer Service)
Fax) +82-31-468-3311

Dealer

Sensorless Vector Inverter SOHO NC Manual



The contents of this manual can be changed without any notice to customers.

Sensorless Vector Inverter SOHO NC Manual

- ◆ 0.75 ~ 2.2 kW / 200V
- ◆ 0.75 ~ 3.7 kW / 400V



! Safety

- ◆ For safe use, please read carefully "safety" and "General" before use.
- ◆ Put this manual in the place out of user's range of vision.



<Precautions before installing SEOHO Inverter and configuration of peripheral devices>

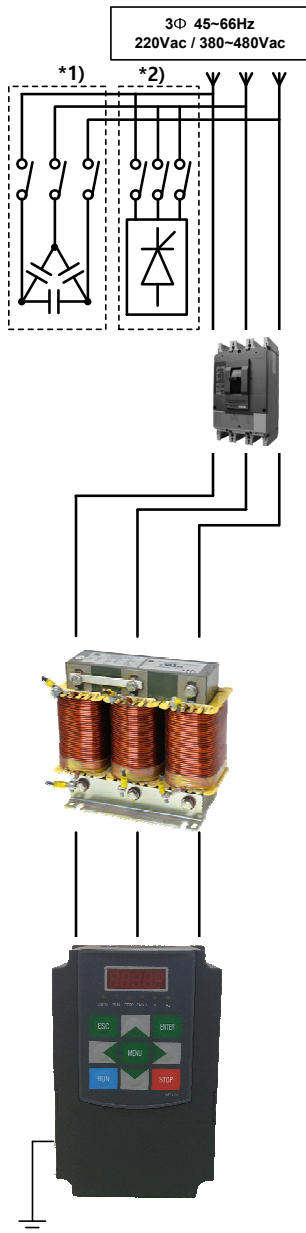

Input Power Source

Should be comply with the power source specifications indicated in this product manual. Be sure to check the AC input reactor installation according to the power facility capacity and the device connected to the same system.

MCCB or ELCB

When power is applied to the inverter, a large inrush current flows, so be careful when selecting a circuit breaker.

AC Input Reactor

Install the AC reactor in the following situations.

1. When the input power facility (transformer) capacity is over 500 kVA, More than 10 times the inverter capacity, or wiring distance is within 10 m.
2. When harmonic current suppression and power factor improvement are required.
- *1)3. When the phase advance capacitor is turned on and off.
- *2)4. AC reactor installation is absolutely necessary when power conversion devices using thyristors, such as DC drives and magnetic cranes, are installed in the same input power supply.
5. If the voltage unbalance rate exceeds 2%

*** For detailed configuration of peripheral devices, please refer to Using Peripheral Devices in Chapter 3 Installation of the User Manual.**

SAFETY

■ Please read carefully Chapter 1, SAFETY, to prevent from accidents or jeopardizes.

■ The meaning of signals is below.

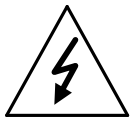

= Caution to electric shock



= Caution to jeopardize

■ Put this manual in the place that is always visible to users.

CONTENTS

<2024-11-Rev.0>

1.	Safety	1-1
1.1	Warning	1-1
1.2	Safety Instruction	1-2
1.3	Wiring	1-3
1.4	Running the Motor	1-3
2.	General	2-1
2.1	Receiving Product	2-1
2.2	Inverter Type	2-1
2.3	Storing and Warranty	2-2
2.4	Power Rating	2-2
2.5	External Dimension	2-4
2.5.1	NC0	2-4
2.5.2	NC1	2-5
2.5.3	NC2	2-5
2.6	Specification	2-6
2.7	System Configuration	2-8
3.	Installation	3-1
3.1	Installation Condition	3-1
3.1.1	Precautions when installing NC0	3-1
3.2	Cooling	3-2
3.3	Use of Auxiliary Equipment	3-3
3.3.1	Input/Output Reactor	3-4
3.4	Dynamic Brake Resistor	3-5
4.	Wiring	4-1
4.1	Caution to Wiring	4-1
4.2	Wiring Diagram	4-3
4.3	Terminal and Bolt Classified by External Dimension	4-6
4.4	Connection of Power Cable and Fuse	4-7
4.4.1	Installation Instruction	4-7
4.4.2	Specification of Wire and Fuse	4-8
4.4.3	Cable and Motor Insulation Check	4-8

1

2

3

4

5

6

7

8

9

10

5.	Consistence of Operation of Main Menu	5-1
6.	Keypad	6-1
6.1	Keypad Description	6-1
6.2	Keypad Operation	6-1
6.2.1	Main Menu Page[0] Operation	6-3
	※ Use of Keypad for Short Time	6-4
	※ Continuous Use of Keypad	6-5
6.2.2	Main Menu Page[1] Drive Monitor	6-6
6.2.3	Main Menu Page[2] Parameter Edit	6-8
6.2.4	Main Menu Page[3] Auto Tuning	6-9
6.2.5	Main Menu Page[4] Fault Record	6-10
6.2.6	Main Menu Page[5] Initialize	6-11
6.2.7	Main Menu Page[6] Password	6-12
6.2.8	Use of MENU KEY(Check of Inverter status)	6-14
7.	Operation	7-1
7.1	Inverter Turning-on Procedure	7-1
7.2	Inverter Operation Procedure (set up for Control Method)	7-1
7.2.1	Open Loop Control Procedure	7-2
7.3	Auto-Tuning Procedure	7-3
7.3.1	Checking Points before Auto Tuning	7-3
7.3.2	Auto Tuning Operation & Completion	7-4
7.4	Basic Open Loop Control Operation Procedure	7-5
7.4.1	Basic Design	7-5
7.4.2	Motor Specification & Open Loop Control Method Setting	7-6
7.4.3	Speed or Frequency Reference & Digital Input Setting	7-9
7.4.4	Digital and Analogue Output Setting	7-10
7.4.5	Operating Pattern Setting	7-11
7.4.6	Brake Control Parameter Setting Using Digital Output	7-15
8.	Parameter	8-1
8.1	Parameter Table	8-1
8.2	Parameter Description	8-16

9.	Protection	9-1
9.1	Warning	9-1
9.2	Parameter Error	9-2
9.3	Parameter Fault	9-2
10.	Troubleshooting	10-1
10.1	Troubleshooting	10-1
10.2	Maintenance and Inspection	10-3

1

2

3

4

5

6

7

8

9

10

1. Safety

1.1	Warning	1-1
1.2	Safety Instruction	1-2
1.3	Wiring	1-3
1.4	Running the Motor	1-3

1. Safety

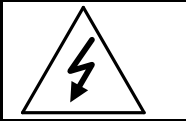

ONLY A COMPETENT ELECTRICIAN SHOULD CARRY OUT THE ELECTRICAL INSTALLATION OR INSPECTION.

1.1 Warning

	1	Internal Components and circuit boards apply an electric current when SOHO NC inverter is connected to the main voltage. This voltage is extremely dangerous and may cause death or severe injury if you come in contact with it.
	2	When SOHO NC inverter is connected to the main power, the current is flowing in the motor connections (U, V, W), DC-Link (P, N) and Dynamic Brake Resistor Connections (R+, R-) even if the motor is not running.
	3	SOHO NC inverter has a large capacitive leakage current.
	4	The control I/O terminals are isolated from the main voltage but the relay outputs and other I/Os may have dangerous voltage connected even if the power is disconnected from the SOHO NC inverter .
	5	If a SOHO NC inverter is used as a part of the machine, the machine manufacturer is obliged to take care that the inverter has a main switch and power fuse in the machine.
	6	Spare parts can be delivered only by SEOHO DRIVES, LTD.

1.2 Safety Instruction

	1	Do NOT make any connections when the SOHO NC inverter is connected to the main voltage.
	2	Do NOT make any measurements when the SOHO NC inverter is connected to the main voltage.
	3	After disconnecting the main power, wait until the cooling fan stops and the indicator of keypad goes out. Wait a further 5 minutes before doing any work on SOHO NC inverter connections. Do NOT open even the cover within this time.
	4	Do NOT make any voltage withstand tests on any parts of the SOHO NC inverter inverter.
	5	Disconnect motor cables from SOHO NC inverter before making any measurements on the motor cables or motors.
	6	Do NOT touch the IC-circuits on the circuit boards. Static voltage discharge may destroy the components.
	7	Make sure that the cover of SOHO NC inverter inverter is closed before connecting the main voltage.

Ground

The ground terminal of **SOHO-NC** has to contact with ground wire. 
Ground of SOHO-NC inverter prevents high voltage accidents that are caused by switching.

Warning Sign

Please be more cautious for the following warning signs for user's safety.



= Dangerous Voltage



= General Warning

1.3 Wiring

	1	Do not connect SOHO NC Inverter input terminal (L1, L2, and L3) power to output terminal (U, V, and W) power. It is caused to the damage of inverter.
	2	Do not supply more than the allowed voltage to SOHO NC Inverter input terminal (L1, L2, and L3). It is caused to the damage of inverter.
	3	Connect SOHO NC Inverter output terminal (U, V, and W) following accurate order.
	4	Do not connect contactor, condenser, and surge filter etc to SOHO NC Inverter output terminal (U, V, and W). It is caused to the malfunction and damage of inverter.
	5	Experts at the electric wiring work must handle for the safety.

1.4 Running the Motor

	1	Before running the motor, be cautious not to have any safety accident. Make sure that the motor is mounted properly. Check the parameters are set properly.
	2	Maximum motor speed (frequency) should always be set according to the motor and machine connected to the motor.
	3	Before reversing the rotation of the motor shaft, make sure that this can be done safely.

This manual describes the specification, installation, operation, function, and keeping and repair of **SOHO NC Inverter**, which is manual for the experienced users of inverter.

For safe use, please read carefully “safety” and “General” before use.

Put this manual in the place that is always visible to users.

2. General

2.1 Receiving Product 2-1

2.2 Inverter Type 2-1

2.3 Storing and Warranty 2-2

2.4 Power Rating 2-2

2.5 External Dimension 2-4

 2.5.1 NC0 2-4

 2.5.2 NC1 2-5

 2.5.3 NC2 2-5

2.6 Specification 2-6

2.7 System Configuration 2-8

2. General

2.1 Receiving Product

SOHO NC inverter is shipped from the factory after performing a performance test before it is supplied to users. Before unpacking, check if the device does not show any sign of damage and any missing parts. (Refer to the label and type in table 2.1-1)

If there is a damage, please contact the insurance company or the SEOHO DRIVES, LTD.

If the delivery is not in compliance with the order, please contact the supplier immediately.

Type	SOHO2.2NC4Y NC1		Inverter model
Serial No.	2420001D		Serial Number
Power Rating	2.2[kW]		Inverter Rated Capacity
Rated Current	5.5[A]	QR code	Inverter Rated Current(When driving constant torque)
Voltage	380V~480V		
			SEOHO DIRVES Logo

Table 2.1-1 Inverter Label (This is attached to both sides of inverter.)

2.2 Inverter Type

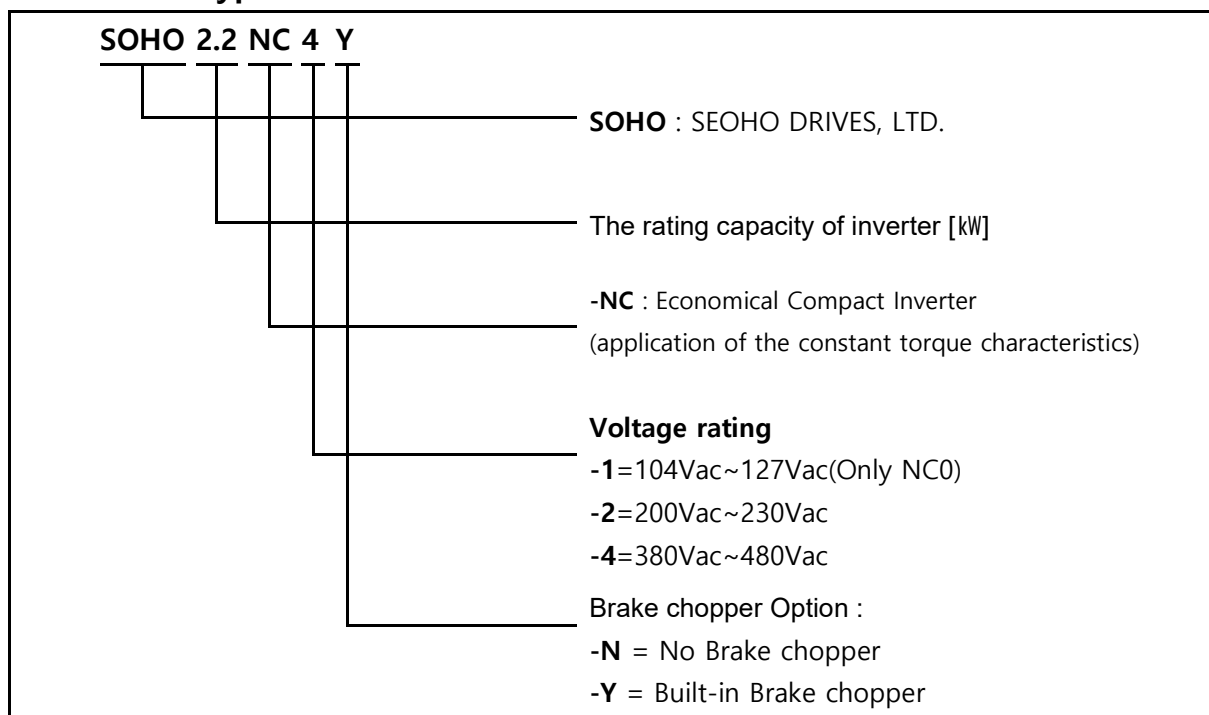

Table 2.2-1 Inverter Type

2.3 Storing and Warranty

Check the ambient conditions in the storage room before the first commissioning. (Temperature: -25[°C]~+55[°C], relative humidity 5[%]~95[%], condensation is not allowed.)

If the instructions above are not followed, SEOHO DRIVES, LTD. shall not responsible for the damage caused as a result.

The period of manufacturer’s warranty is 12 months from the date of delivery by factory.

The local distributor may have a different warranty period, which is specified in the condition of sale and condition of warranty. If any queries concerning the warranty arise, please contact your distributor.

2.4 Power Rating

2.4.1 100V NCO Inverter output rating

I_{CT} = rated output current (constant torque load)

Main Voltage 104V - 127V, 50/60Hz NCO Series					
Inverter Type	Rated Output Power and Rated Current		Size / IP	Dimension W×H×D (mm)	Weight (kg)
	P[kW]	I_{CT} [A]			
SOHO 1.5 NCO 1Y	1.5	14	NCO ⁽¹⁾ / IP00	123 X 130 X 100	1.2

(1) NCO do not have a cooling fan. (Require separate cooling system)

Table 2.4-1 100V NCO Series Power ratings and dimensions

2.4.2 200V NCO Inverter output rating

I_{CT} = rated output current (constant torque load)

Main Voltage 200V - 230V, 50/60Hz NCO Series					
Inverter Type	Rated Output Power and Rated Current		Size / IP	Dimension W×H×D (mm)	Weight (kg)
	P[kW]	I_{CT} [A]			
SOHO 1.5 NCO 2Y	1.5	7	NCO ⁽¹⁾ / IP00	123 X 130 X 100	1.2

(1) NCO do not have a cooling fan. (Require separate cooling system)

Table 2.4-2 200V NCO Series Power ratings and dimensions

2.4.3 200V NC1_2 Inverter output rating

I_{CT} = rated output current (constant torque load)

Main Voltage 200V - 230V, 50/60Hz NC1_2 Series					
Inverter Type	Rated Output Power and Rated Current		Size / IP	Dimension W×H×D (mm)	Weight (kg)
	P[kW]	I_{CT} [A]			
SOHO 0.75 NC 2Y	0.75	3.9	NC1 / IP00	105 X 161 X 136	1.2
SOHO 1.5 NC 2Y	1.5	7.4	NC1 / IP00	105 X 161 X 136	1.2
SOHO 2.2 NC 2Y	2.2	10.1	NC2 / IP00	125 X 185 X 161	1.9

Table 2.4-3 200V NC1_2 Series Power ratings and dimensions

2.4.4 400V NC0 Inverter output rating

I_{CT} = rated output current (constant torque load)

Main Voltage 380V - 480V, 50/60Hz NC0 Series					
Inverter Type	Rated Output Power and Rated Current		Size / IP	Dimension W×H×D (mm)	Weight (kg)
	P[kW]	I_{CT} [A]			
SOHO 1.5 NC0 4Y	1.5	3.5	NC0 ⁽¹⁾ / IP00	123 X 130 X 100	1.2

(1) NC0 do not have a cooling fan. (Require separate cooling system)

Table 2.4-4 400V NC0 Series Power ratings and dimensions

2.4.5 400V NC1_2 Inverter output rating

I_{CT} = rated output current (constant torque load)

Main Voltage 380V - 480V, 50/60Hz NC1_2 Series					
Inverter Type	Rated Output Power and Rated Current		Size / IP	Dimension W×H×D (mm)	Weight (kg)
	P[kW]	I_{CT} [A]			
SOHO 0.75 NC 4Y	0.75	2.5	NC1 / IP00	105 X 161 X 136	1.2
SOHO 1.5 NC 4Y	1.5	4.0	NC1 / IP00	105 X 161 X 136	1.2
SOHO 2.2 NC 4Y	2.2	5.5	NC1 / IP00	105 X 161 X 136	1.2
SOHO 3.7 NC 4Y	3.7	9.2	NC2 / IP00	125 X 185 X 161	1.9

Table 2.4-5 400V NC1_2 Series Power ratings and dimensions

2.5 External Dimension

SOHO NC inverter must be secured to the mounting surface. The inverter shall be installed in a perpendicular to the wall or to the side of the control panel. Space conditions for cooling shall be met. See Chapter “3.2 Cooling” for installation distance.

To ensure a safe installation, make sure that the mounting surface is relatively flat.

Fixing is done with four or more screws or bolts depending on the size of the unit. Refer to Figure 2.5-1 ~ 2.5-3.

2.5.1 NC0

*NC0 do not have a cooling fan. (Require separate cooling system)

Voltage	Model	Voltage	Model	Voltage	Model
100V	1.5 NC0 1Y	200V	1.5 NC0 2Y	400V	1.5 NC0 4Y

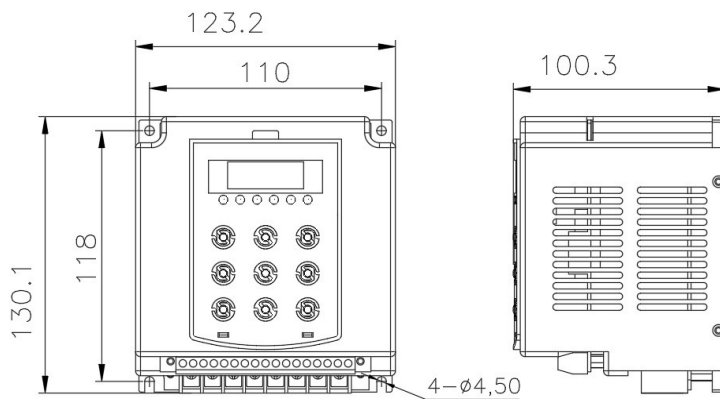

Figure 2.5-1 NC0 External dimension

2.5.2 NC1

Voltage	Model
200V	0.75 NC 2Y
	1.5 NC 2Y

Voltage	Model
400V	0.75 NC 4Y
	1.5 NC 4Y
	2.2 NC 4Y

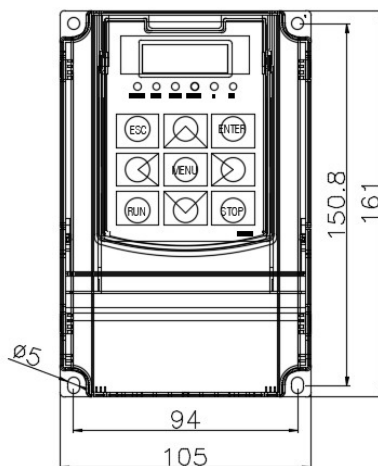
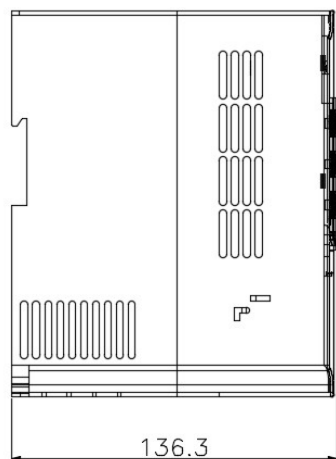

Figure 2.5-2 NC1 External dimension

2.5.3 NC2

Voltage	Model
200V	2.2 NC 2Y

Voltage	Model
400V	3.7 NC 4Y

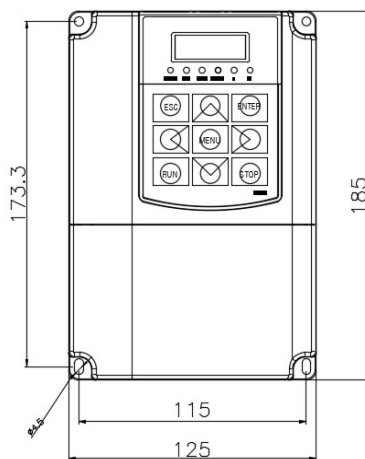
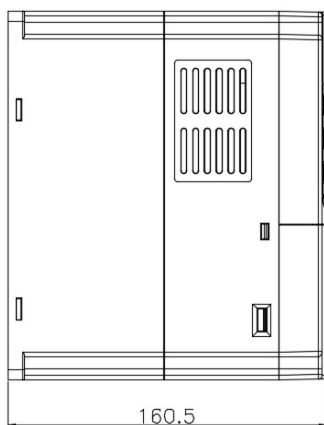

Figure 2.5-3 NC2 External dimension

2.6 Specification

Main Connection	Input Voltage V_{in} ($\pm 10\%$)	104V _{ac} ~ 127V _{ac} , 200V _{ac} ~ 230V _{ac} , 380V _{ac} ~ 480V _{ac}		
	Input Frequency	50Hz ~ 60Hz ($\pm 10\%$)		
	Connection to the Main	Don't turn on and off the inverter more than 1 times within 1 min.		
Rated Output	Output Voltage	0 ~ 95% of V_{in}		
	Continuous Output current	I _{CT} : ambient max. +40°C Over load 1.35×I _{CT} (1min./10min.)		
	Starting Torque	150%~200% (0.5Hz) on Sensor less V/F Control 150% ~200% (0Hz) on Sensor less Vector Control		
	Output Frequency/speed	Sensor less Vector & V/F: 0~300.0[Hz] / 3000[Hz](optional)		
	Frequency/speed resolution	Sensor less V/F: 0.01[Hz] / 0.1[Hz] Sensor less : 1[rpm]		
Control	Control Method	Sensor less V/F Frequency Control Sensor less Vector Speed Control Sensor less Torque Control		
	Switching Frequency	1.0 ~ 10.0[kHz]	100V	1.5kW
			200V	0.75kW ~2.2kW
			400V	0.75kW ~3.7kW
	Frequency reference	Analog I/P	Resolution 10bit, Degree of precision $\pm 0.1\%$	
		Keypad	Resolution 0.01Hz / 0.1Hz	
	Field weakening point	Auto Tuning		
Acceleration Time	V/F Control - 0.5 ~ 3000.0[sec] Sensor less Vector Control - 0.00 ~ 3000.00[sec]			
Deceleration Time	V/F Control - 0.5~3000.0[sec] Sensor less Vector Control - 0.00 ~ 3000.00[sec]			
Environmental Limits	Operating Air Temperature	-10°C ~ +40°C (A place free from freezing)		
	Relative Humidity	< 90%, no condensation allowed		
Protection Function	Over Voltage, Over Current, Over Load, Zero Current, Low Current, Low Voltage. Motor Over Speed, Out of Control, Over Temperature, IGBT Short Circuit, Motor Short Circuit, Initial Recharge Fault, External Fault Signal Detection, Gate Drive Main Power and Wiring Fault Detection, Keypad Communication Fault Detection, Auto Tuning Fault Detection, Software Default Detection			

<Next>

<Continued>

Control I/O Specification	Analog Input voltage		0V(-10V) ~ +10V _{DC} , resolution 10bit
	Analog Input current		0(4) ~ 20mA, resolution 10bit
	Digital Input		Negative Logic
	Aux. supply Voltage		+24V ±20%, Max. 100mA
	Analog Output		0 (or 4) ~ 20mA, resolution 10bit
	Relay Output	DO1	Multi-Function Output : AC 250V/3.5A or DC 30V/3.5A
DO2		Multi-Function Output : AC 250V/3.5A or DC 30V/3.5A	

2.7 System Configuration

2

Figure 2.7-1 shows a block diagram of the **SOHO NC inverter**.

The diode bridge rectifies the three-phase power to supply the inverter with DC power. An inverter configured as an IGBT provides 3-phase symmetrical AC voltage to the motor.

Motor control blocks are based on microprocessor software. The microprocessor controls the motor according to the type of program (V/F, Vector) and measurement signals built into the flash memory and according to control I/O blocks and parameter settings and commands on the panel. It then calculates the IGBT switching pulse changes and drives the IGBT through the gate driver.

The gate driver amplifies the modulation signal to drive the IGBT inverter. When the IGBT receives an over-current, it disconnects the IGBT gate signal and sends it to the microprocessor. KEYPAD is the connector between the user and the **SOHO-NC inverter**. With the keypad or PC, the user can set parameter values, read data, and even make control commands.

The keypad can be removed and mounted to external, and connected to the **SOHO-NC inverter** using a cable.

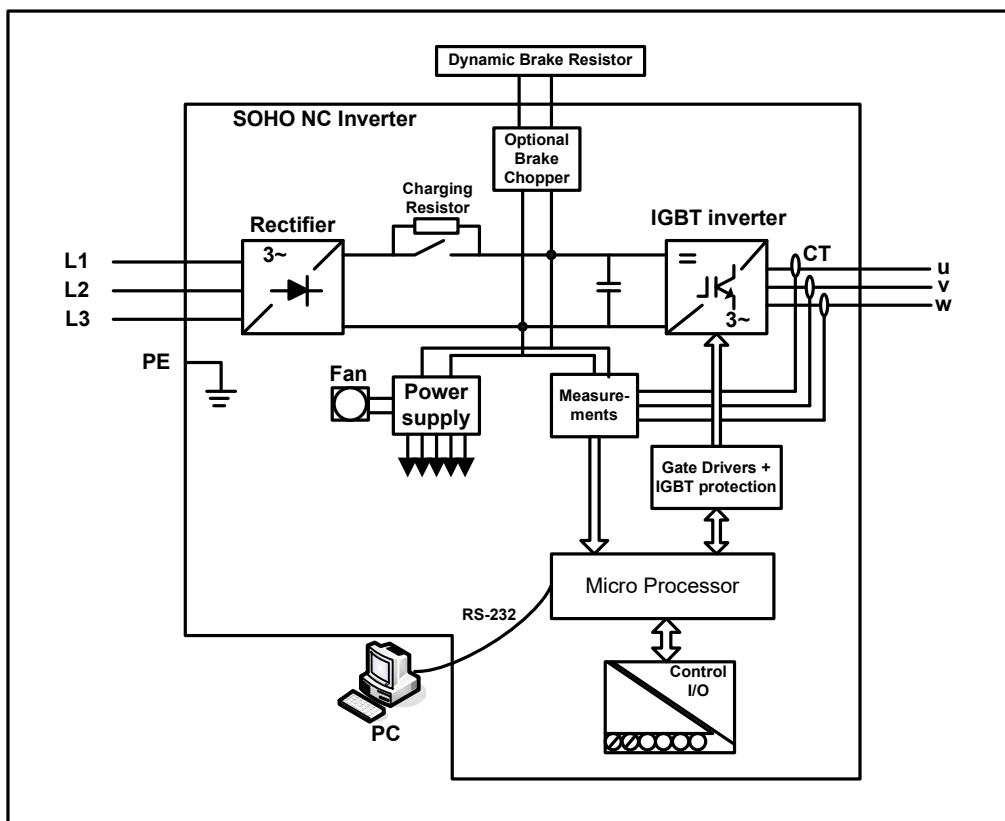

Figure 2.7-1 NC inverter Block Diagram

3. Installation

3.1	Installation Condition	3-1
3.1.1	Precautions when installing NC0	3-1
3.2	Cooling	3-2
3.3	Use of Auxiliary Equipment	3-3
3.3.1	Input/Output Reactor	3-4
3.4	Dynamic Brake Resistor	3-5

3. Installation

3.1 Installation Condition

Please install **the SOHO NC inverter** on the places satisfying the following conditions.

	1	Avoid rain, hot temperature and high humidity place.
	2	Avoid the direct sunlight.
	3	The place should be protected from dirt, metal dust, and welding flame.
	4	Install in low-vibration areas.
	5	Defective main power may cause the inverter damages. - Using the same power source with welding machine - Using a generator as the power source - Sudden changes in the main voltage.
	6	Keep away from flammables.
	7	Install on the surface of nonflammable material such as metal.

3.1.1 Precautions when installing NC0



Warning

Since NC0 is not designed for heat dissipation, **if there is a space** between the panel surface and the inverter heat sink as shown below, **it may cause inverter failure.**

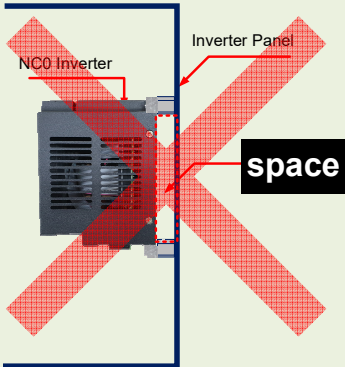

As shown below, **the inverter must be installed in close contact so that there is no space** between the panel surface and the inverter heat sink.

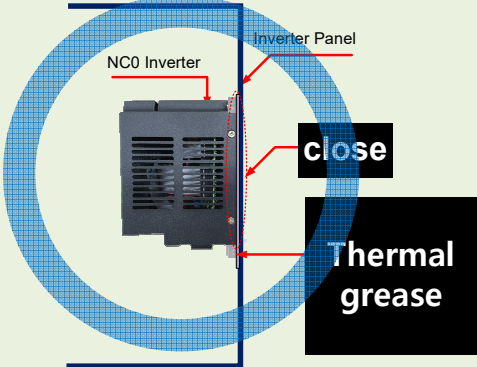

1. Use thermal grease or a thermal pad for close contact between the panel and the inverter heat sink.
2. For panels, use a steel plate of 2mm or more with an external surface area of 1200cm² or more.

Figure 3.1.1 Precautions when installing NC0

3.2 Cooling

3

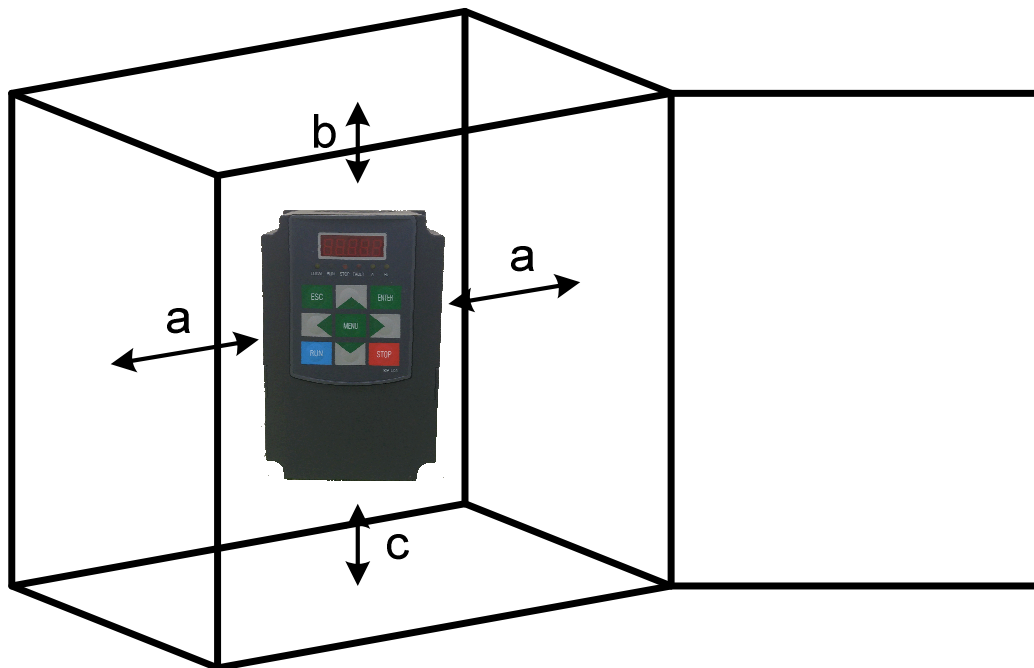

Figure 3.2-1 Installation space

The specified space around the **SOHO NC inverter** unit ensures proper cooling air circulation. See table 3.2-1 for dimensions. If multiple units are to be installed above each other, the distance between the units must be $b + c$ and air from the outlet of the lower unit must be directed away from the inlet of the upper unit.

SIZE	Dimension(mm)		
	a	b	c
NC0/NC1/NC2	20	150	50

Table3.2-1 Installation space dimension

3.3 Use of Auxiliary Equipment

When using a **SOHO NC Inverter**, it is recommended to use right auxiliary equipments. If the auxiliary equipments are not right for SOHO NC inverter, it can cause damage to the inverter. Therefore, follow the recommended specifications for configuration.

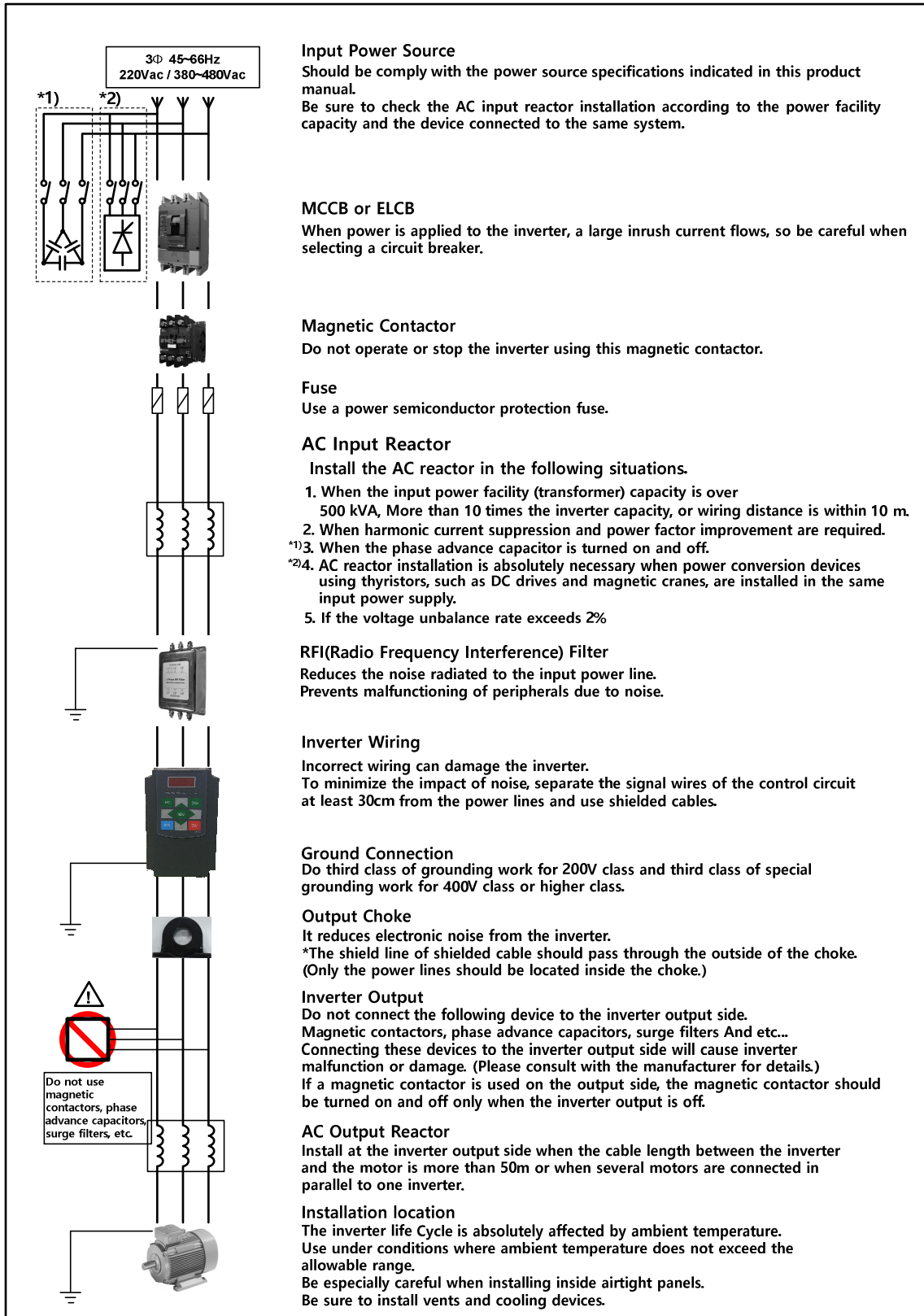

Figure 3.3-1 auxiliary equipment

3.3.1 Input/Output Reactor

<400V - 50Hz, 60Hz>

Voltage	Capacity	Freq.	Input Reactor (V _o =2%)		Output Reactor		Note
			Current	Induct.	Current	Induct.	
400V	0.75kW	60Hz	3A	7.34mH	3A	3228uH	1. A permissible error of inductance- ±5% 2. An allowable inductance in over current - Keep inductance over 80% in 150% current. 3. A permissible temperature (100% load) - Reactor temperature below 100°C in ambient temperature 40°C 4. Switching frequency (only for output reactor): 5kHz
	1.5kW	60Hz	5A	4.59mH	5A	2017uH	
	2.2kW	60Hz	7A	3.06mH	7A	1345uH	
	3.7kW	60Hz	10A	2.04mH	11A	897uH	
	0.75kW	50Hz	3A	8.80mH	3A	3873uH	
	1.5kW	50Hz	5A	5.50mH	5A	2421uH	
	2.2kW	50Hz	9A	2.75mH	10A	1211uH	
	3.7kW	50Hz	11A	2.20mH	12A	969uH	

Table 3.3-1 400V - 50Hz, 60Hz Input/output reactor

<200V - 50Hz, 60Hz>

Voltage	Capacity	Freq.	Input Reactor (V _o =2%)		Output Reactor		Note
			Current	Induct.	Current	Induct.	
200V	0.75kW	60Hz	3A	3.93mH	4A	1730uH	1. A permissible error of inductance- ±5% 2. An allowable inductance in over current - Keep inductance over 80% in 150% current. 3. A permissible temperature (100% load) - Reactor temperature below 100°C in ambient temperature 40°C 4. Switching frequency (only for output reactor): 5kHz
	1.5kW	60Hz	6A	1.97mH	7A	865uH	
	2.2kW	60Hz	9A	1.46mH	9A	640uH	
	0.75kW	50Hz	3A	4.72mH	4A	2076uH	
	1.5kW	50Hz	6A	2.36mH	7A	1038uH	
	2.2kW	50Hz	9A	1.75mH	9A	768uH	

Table 3.3-2 200V - 50Hz, 60Hz Input/output reactor

Caution.1)

In table input reactor is suitable for inverter applied nominal torque operation like hoist and lift.

The value of input reactor suited variable torque operation like fan, pump and etc., is calculated by the capacity of capacitor bank and the built-in of DC reactor so that input reactor should be selected carefully.

Caution.2)

It is necessary to use the output reactor, when the distance between inverter and motor is over 50m or over 2 motors are connected with one inverter.

If the distance between inverter and motor is over 100m, the output reactor should be over 2 times of the inductance in left table.

※ 3.7kW_400V Input Reactor External Dimension

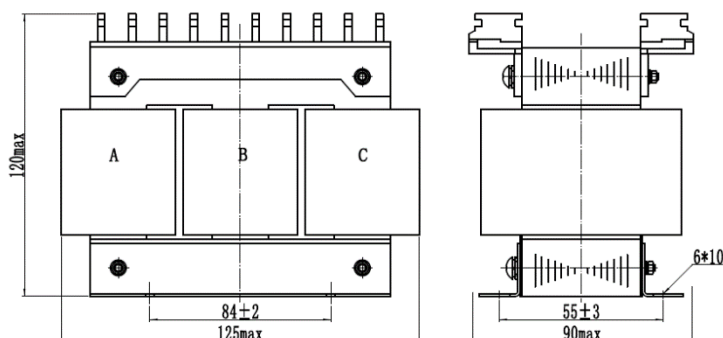

Figure 3.3-2 Input Reactor External Dimension

3.4 Dynamic Brake Resistor

See table 3.4-1 for the standard brake resistor of SOHO-NC

Please, ask the factory or the head office for details on recommended DBR for vertical loads and equipments that have a high frequency in use.

Voltage	Model	DBR resistor [Ω]	DBR capacity[kW] 60%ED	DBR capacity[kW] 25%ED
400V	SOHO 0.75 NC 4Y	500	0.5	0.2
	SOHO 1.5 NC 4Y	200	0.9	0.4
	SOHO 2.2 NC 4Y	150	1.4	0.6
	SOHO 3.7 NC 4Y	100	2.3	1.0
200V	SOHO 0.75 NC 2Y	150	0.5	0.2
	SOHO 1.5 NC 2Y	60	0.9	0.4
	SOHO 2.2 NC 2Y	50	1.4	0.6

Table 3.4-1 Standard Brake Resistor

4. Wiring

4.1	Caution to Wiring	4-1
4.2	Wiring Diagram	4-3
4.3	Terminal and Bolt Classified by External Dimension	4-6
4.4	Connection of Power Cable and Fuse	4-7
4.4.1	Installation Instruction	4-7
4.4.2	Specification of Wire and Fuse	4-8
4.4.3	Cable and Motor Insulation Check	4-8

4. Wiring

4.1 Caution to wiring

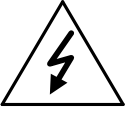
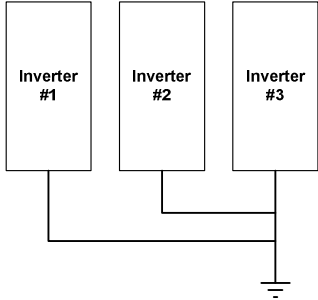
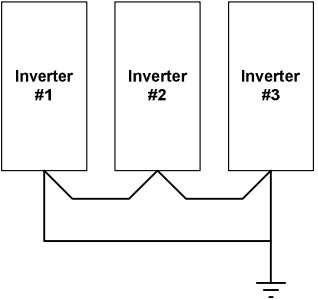
	1	<p>Connect the ground cable surely. If multiple units are installed together, the ground does not make the loop. Refer to below picture.</p> <div style="display: flex; justify-content: space-around; align-items: center;"> <div style="text-align: center;">  <p><i>(a) Good</i></p> </div> <div style="text-align: center;">  <p><i>(b) NOT good</i></p> </div> </div>
	2	Only a competent electrician should carry out the wiring
	3	Make sure that the input main voltage is switched off.
	4	Do NOT connect AC power source to the output terminals (U, V, W).
	5	In the case of installing an earth leakage breaker at the input (L1, L2, L3), Make inquiries to a competent electrician for the set-up of leakage current.
	6	Power cables, the earth leakage breaker and a Magnetic contactor should be used with the rated capacity.
	7	Attach surge filters to the Magnetic contactors that are installed around inverter.
	8	Installing Static Condenser or Surge Suppressor on the output of Inverter is prohibited. In case of installed already, please remove.
	9	Do NOT run or stop the inverter directly with a Magnetic Contactor installed in the input(L1, L2, L3) and output(U, V, W).
	10	Make sure that no loose connections are made.
	11	The length of wire connected output lines to motor should be within 50[m]. In case of multi connection with several motors by only one Inverter, the total length of wire between Inverter and motors should be within 50[m]. If the length of all wires connected to each device is inevitably over 50[m], install AC Reactor between output lines of Inverter and motors.
	12	When several motors are running by one inverter, install a thermal relay for each.

<Next>

<Continued>

4

13

Use twisted and shielded cable for signal cables. For encoder signal cables, the wire in the cable should be twisted and shielded by twos. Although the encoder signal cables have a good quality, they could be affected by surrounding noises during wiring. It needs a special attention. The same applies to the communication lines for fieldbus communication.

14

The signal cables must be isolated from the power cables. For an unavoidable case, install perpendicular to each other as shown below.

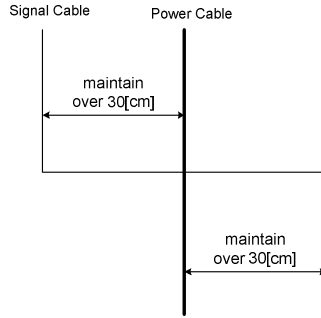

15

If more than **two inverters** are installed, refer to the figure below when installing the AC Reactor.

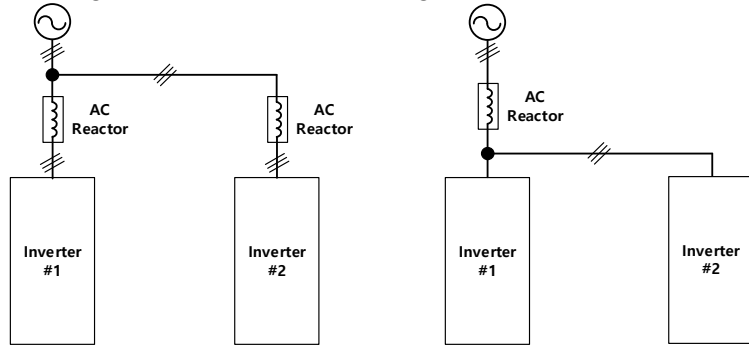

(a) Example of correct AC Reactor connection

(b) Example of incorrect AC Reactor connection

16

If more than **two inverters** are installed, refer to the figure below when installing the Harmonic Filter.

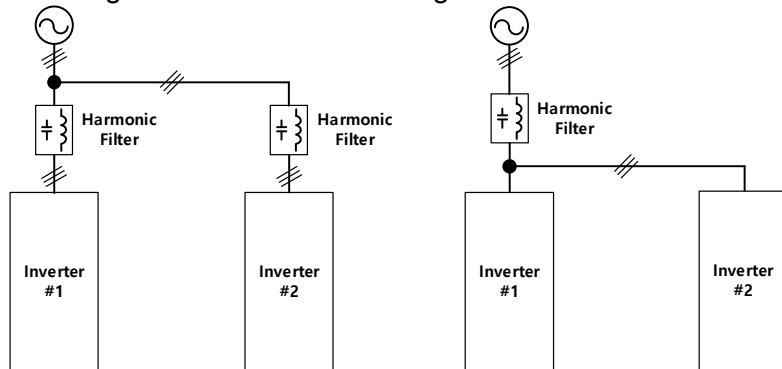

(a) Example of correct Harmonic Filter connection

(b) Example of incorrect Harmonic Filter connection

4.2 Wiring Diagram

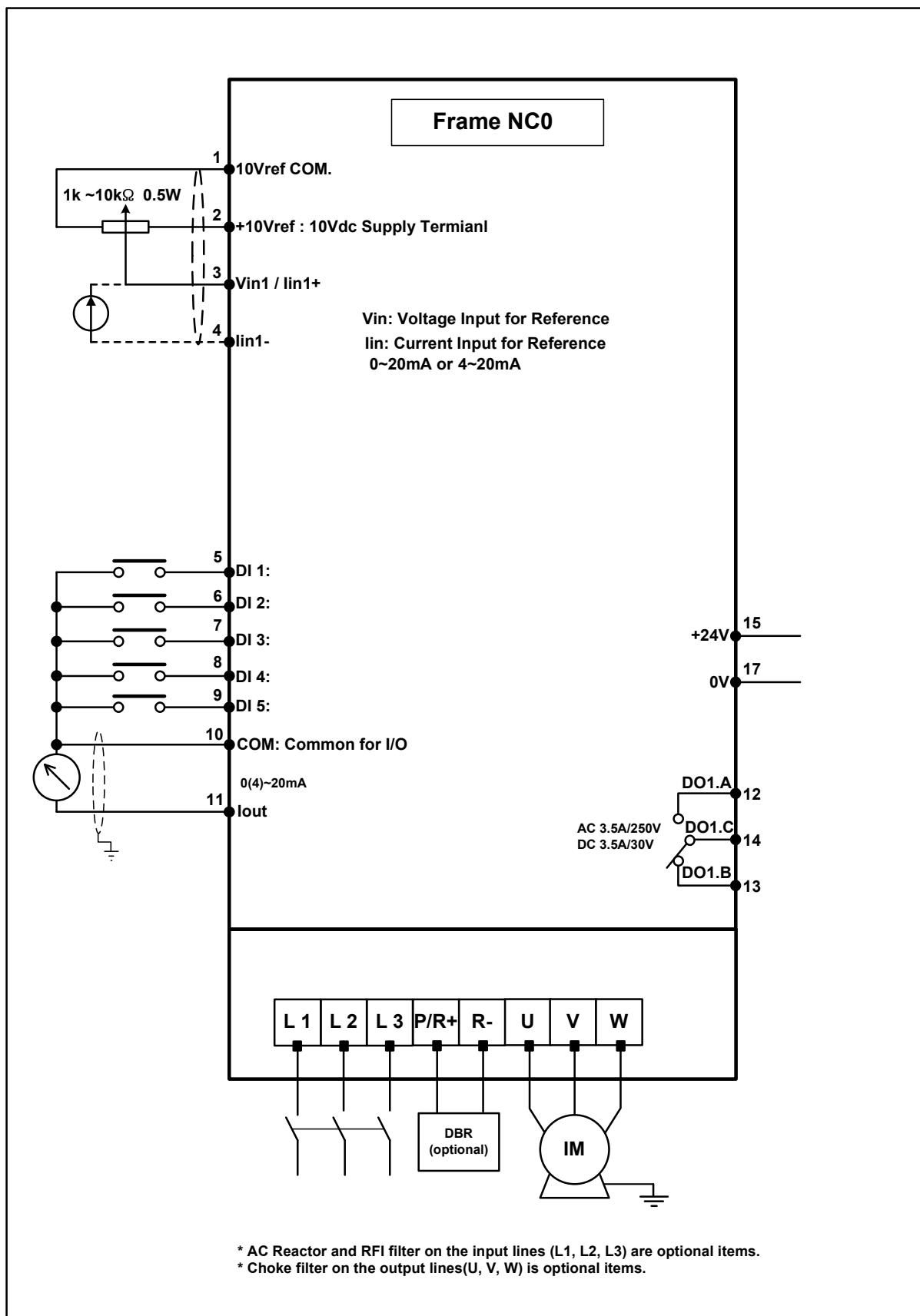

Figure 4.2-1 General wiring diagram of SOHO NC Inverter Frame NC0

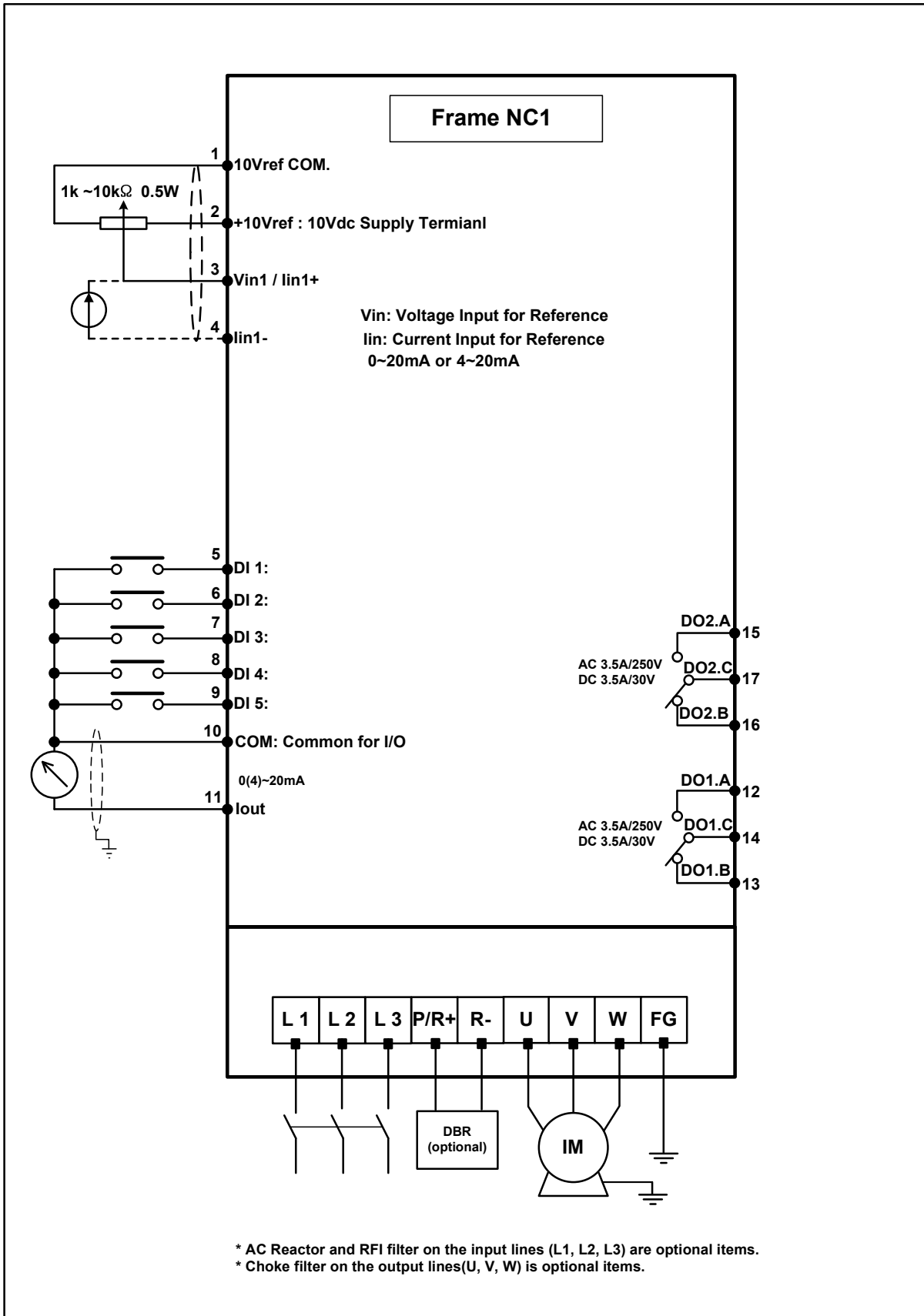

Figure 4.2-2 General wiring diagram of SOHO NC Inverter Frame NC1

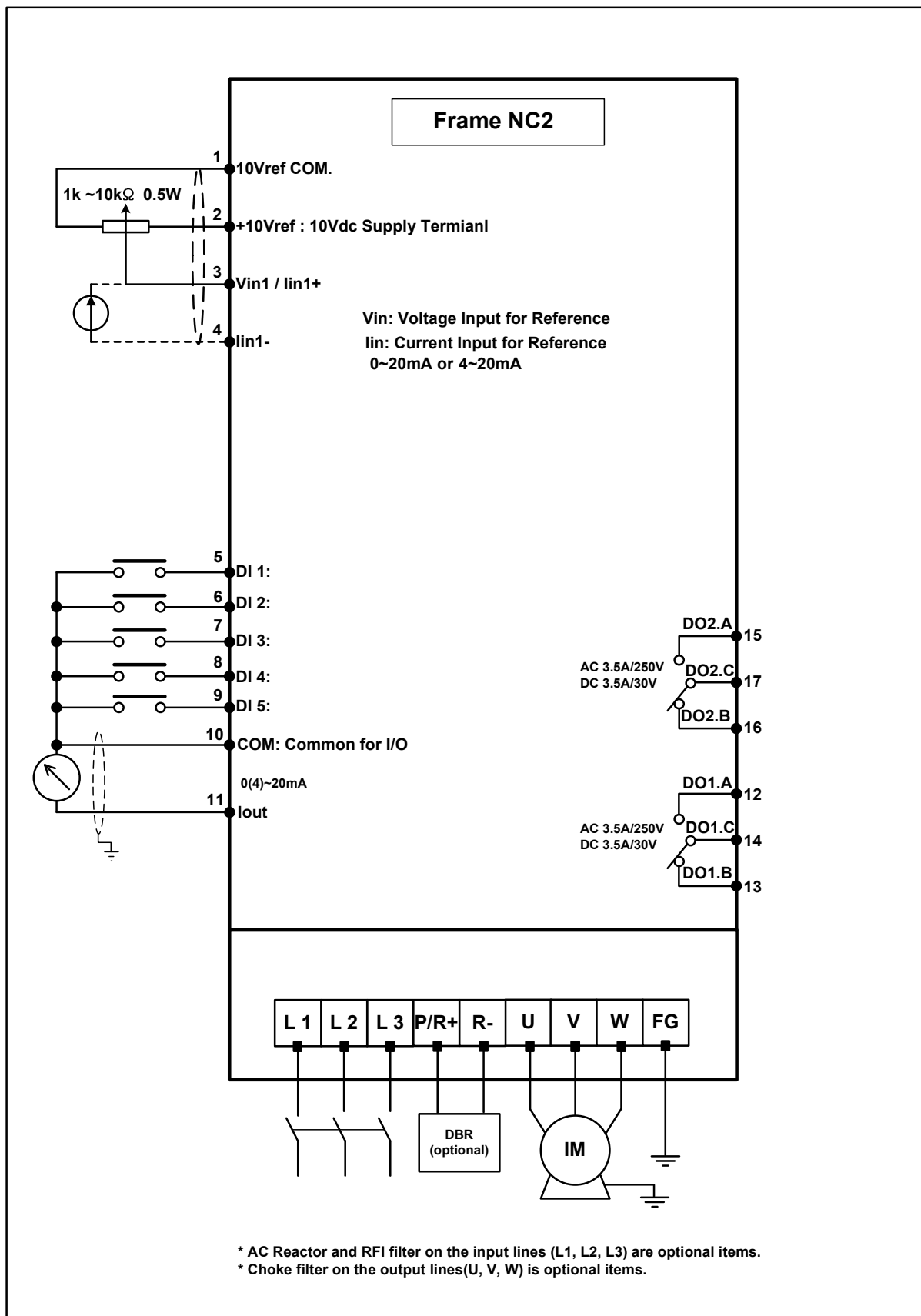

Figure 4.2-3 General wiring diagram of SOHO NC Frame NC2

4.3 Terminal and Bolt Classified by External Dimension

4



Voltage	Frame	Input-Output Wiring				Ground Wiring		
		Terminal	Terminal width (internal)	Bolt size	Torque for tightened (N·m)	Bolt size	Place for the tightened	Torque for tightened (N·m)
200V 400V	NC0	Fixed 	10mm	M4	1.5~2	-	-	-
200V 400V	NC1	Fixed 	7.62mm	M3	1.5~2	M3	External	1.5~2
200V 400V	NC2	Fixed 	9.52mm	M4	1.5~2	M4	External	1.5~2

Table 4.3-1 NC Terminal and bolt classified by external on NC

4.4 Connection of Power Cable and Fuse

Use heat-resistant cables (600V, +70°C or higher). The Power cables and the fuses have to be dimensioned in accordance with the rated output current of the unit and the size of the cables. The minimum dimensions for the Cu-cables and corresponding fuses are given in the table 4.4-1.

If more than 3 cables are used in parallel, please be cautious for that every cable must have its own overload protection.

These instructions concern the cases about that there is one motor and one cable connection from the inverter to the motor.

For other cases, ask the factory for more information.

4

4.4.1 Installation Instruction

	1	<p>Place the motor cables further away from the other cables.</p> <ul style="list-style-type: none"> - Avoid long parallel runs with other signal cables. - The maximum motor cable is 50m. - Must cross at right angles to other signal wires.
	2	See chapter 4.4.3 for cable insulation check.
	3	<p>Connecting cables:</p> <ul style="list-style-type: none"> -Remove the cover of the motor and power cables. -Open the cover of SOHO NC inverter. -Connect the motor and control cables to the correct terminals. (refer to Figure 4.2-1~3) -Check if control cables do not make any contacts with electrical components in the device. -Connect the brake resistor cable (optional). -Ensure the earth cable is connected to the earthing terminal of the inverter. -Connect the separate shield of power cables to motor, supply panel and the protective earth of the inverter. -Ensure that the external control cable or internal wirings are not trapped between the cover and the body of the unit.

4.4.2 Specification of Wire and FUSE

Voltage	400V			200V		
	I/O Cable [mm ²]	Ground cable [mm ²]	FUSE (500V) [A]	I/O Cable [mm ²]	Ground cable [mm ²]	FUSE (500V) [A]
0.75	2	2	5	2.5	2.5	10
1.5	2.5	2.5	10	2.5	2.5	10
2.2	2.5	2.5	10	3.5	3.5	15
3.7	3.5	3.5	15			

Table 4.4-1 Cable and Fuse classified by capacity

Caution

- 1) Use a copper cable, 600V, 75°C.
- 2) High Speed Fuse is recommendable.

4.4.3 Cable and Motor Insulation Check

Order	Checking Item
Check 1	Motor Cable Insulation Check
	Disconnect the motor cables from the output terminals (U, V and W). Measure the insulation resistance of the motor cables between each phase, motor cable and earthing cables. The insulation resistance must be $\geq 1\text{M}\Omega$.
Check 2	Main power cable Insulation Check
	Disconnect the main power cables from the terminals (L1, L2 and L3) and supply panel. Measure the insulation resistance of the main power cables between each phase, and earthing cables. The insulation resistance must be $\geq 1\text{M}\Omega$.
Check 3	Motor Insulation Check
	Disconnect the motor cables from the motor. Measure the insulation resistance of each motor winding. The measurement voltage has to be at least equal to the main voltage but not exceed 1000V. The insulation resistance must be $\geq 1\text{M}\Omega$.

5. Consistence of Operation of Main Menu

5. Consistence of Operation of Main Menu

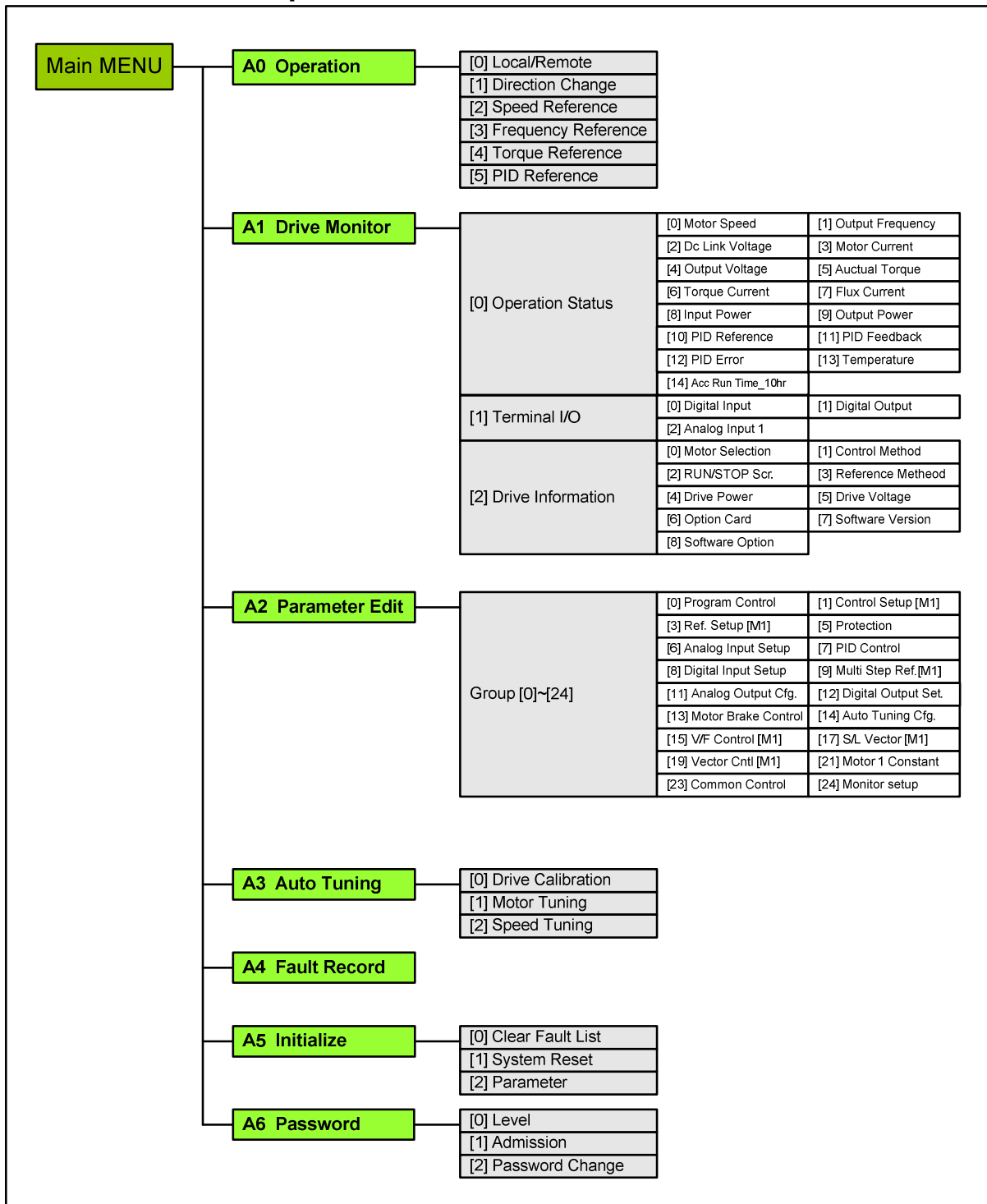

5

Figure 5-1 Consistence of Inverter Main Menu

6. Keypad

6.1	Keypad Description	6-1
6.2	Keypad Operation	6-1
6.2.1	Main Menu Page[0] Operation	6-3
※	Use of Keypad for Short Time	6-4
※	Continuous Use of Keypad	6-5
6.2.2	Main Menu Page[1] Drive Monitor	6-6
6.2.3	Main Menu Page[2] Parameter Edit	6-8
6.2.4	Main Menu Page[3] Auto Tuning	6-9
6.2.5	Main Menu Page[4] Fault Record	6-10
6.2.6	Main Menu Page[5] Initialize	6-11
6.2.7	Main Menu Page[6] Password	6-12
6.2.8	Use of MENU KEY(Check of Inverter status)	6-14

6. Keypad

6.1 Keypad Description

The keypad of **SOHO NC inverter** is composed with 9 keys, (ESC, ENTER, RUN, STOP, MENU, Left, Right, UP and Down scroll key), as shown in Figure 6-1. Users can set up parameters and monitor the operation status and start/ stop the motor with keypad, etc.

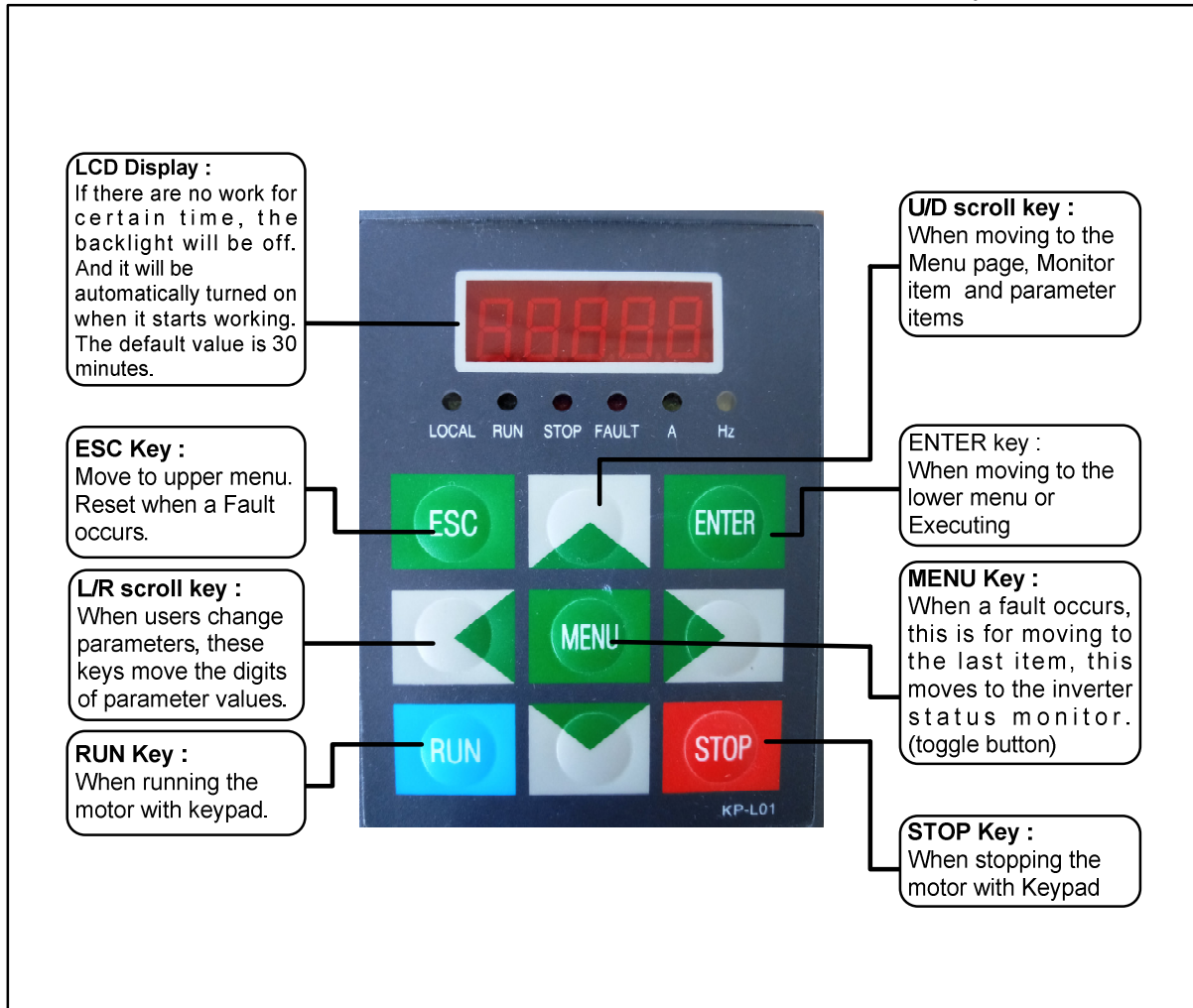



Figure 6.1-1 KEYPAD

6.2 Keypad Operation

The data of KEYPAD is composed with Main Menu and low-level sub-Menu as Figure 6.2-1. Push the button, **ENTER** to move from Main Menu to low-level sub-Menu. And Push the button, **ESC**, to escape from low-level sub-Menu to Main Menu. Use the buttons, , to Increase or decrease the data value. Use the button, , to move cursors when setting-up parameters. When monitoring/checking the status of inverter and listing the Error/Fault, use the button, **MENU**. When operating by KEYPAD, users can start/stop the motor with the buttons, **RUN** and **STOP**. The detailed usage can be referred from chapter 6.2.1 ~ 6.2.8.

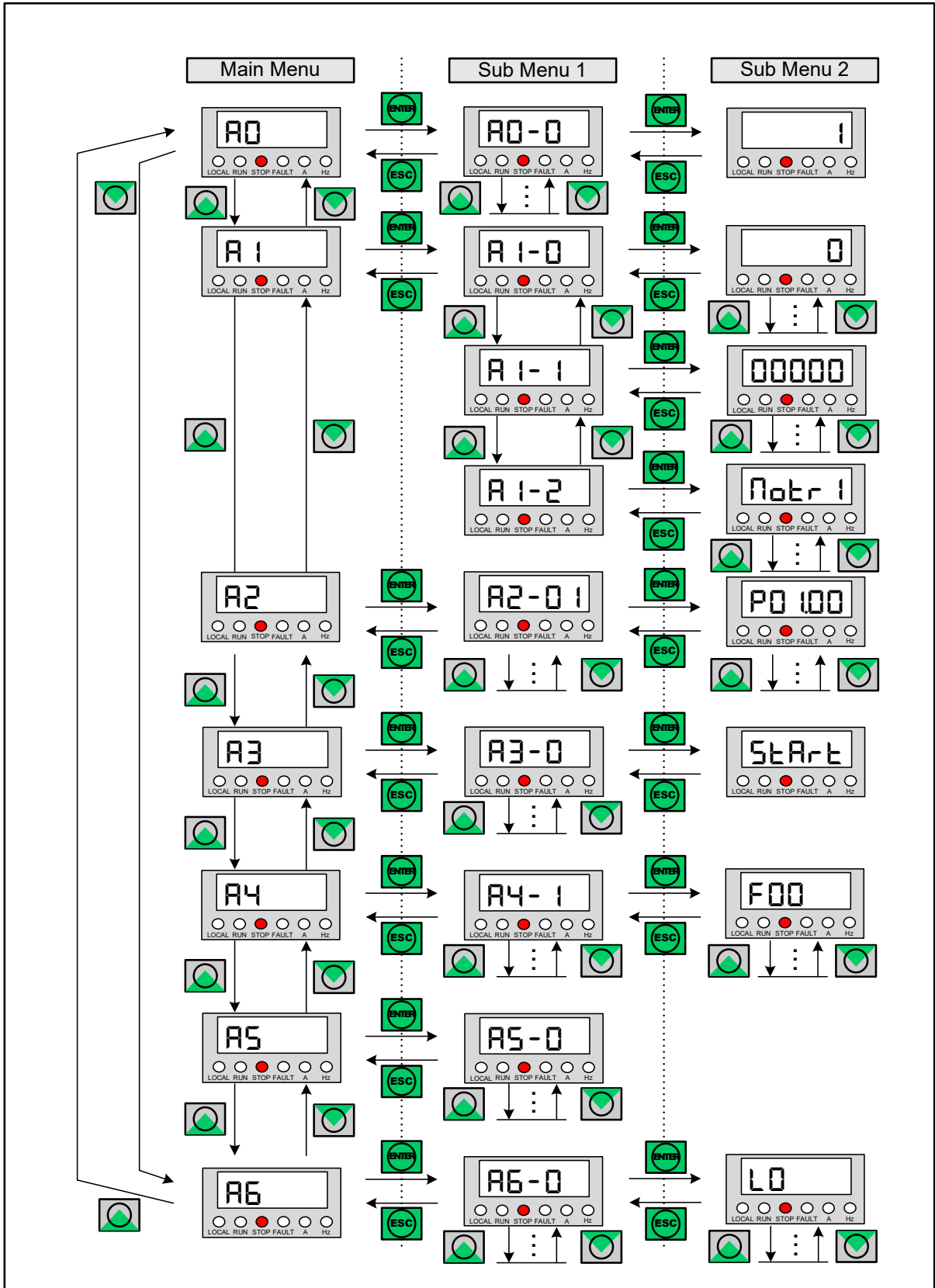

Figure 6.2-1 KEYPAD usage

6.2.1 Main Menu Page [0] Operation

In [A0] operation page, when operating motor that is connected to the SOHO-NC inverter with keypad without any I/O terminal connections, it allows to set up the rotating direction, speed, frequency, torque reference and PID reference. Refer to Figure 6.2-2.

When operating (start or stop) the motor by KEYPAD, use the button, **RUN** / **STOP** and parameter P03.00 and P03.01 are available if they are set on the keypad or if [A0-0] is [0]. Refer to parameter description and the figure below for setting instruction.

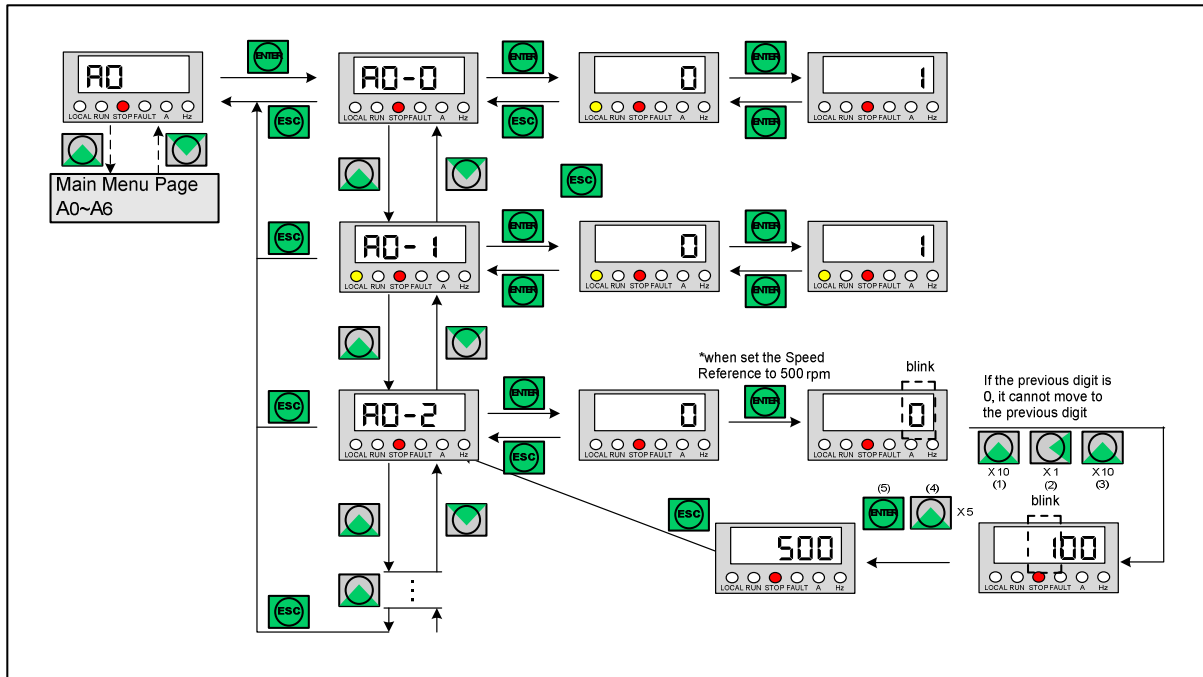

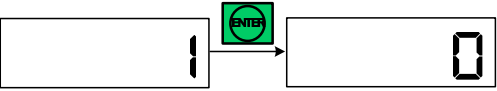
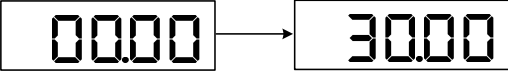

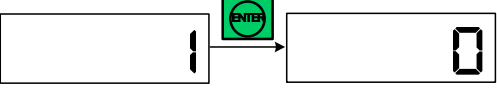



Figure 6.2-2 "[A0] Operation" Menu Page usage





No	M0 Operation	LED Display	Unit	Description
[0]	Local / Remote	RD-0		Change the route of the " Run/STOP " and the authorization of command value from a method other than the keypad (terminal, communication, or other) to a keypad.
	LOCAL REMOTE	0 1		
[1]	Direction Change	RD-1		When operating the inverter by KEYPAD, this sets the direction of rotation of motor whenever users push the button, ENTER
	FORWARD REVERSE	0 1		
[2]	Speed Reference	RD-2	rpm	This sets the speed reference if the Control Method is S/L Vector Speed or Vector Speed control.
[3]	Frequency Reference	RD-3	Hz	This sets the frequency reference if the Control Method is V/F Frequency or V/F Speed control.
[4]	Torque Reference	RD-4	Nm	This sets the torque reference if the Control Method is S/L Vector Torque or Vector Torque control.
[5]	PID Reference	RD-5	%	This sets the reference for PID process control.

※ Use of Keypad for Short Time.

	STEPS	DESCRIPTION
1	Input the main voltage	Caution! There should be no "RUN" signal at the same time of inputting the main voltage.
2		This is the initial screen when the inverter is ready to operate after it is turned on. ([A1] Drive Monitor Page)
3		Move to [A0] Operation Menu Page
4		"[LOCAL]" should be set to use keypad. When it is set to "[Remote]", keypad cannot be used instead the inverter is operated by the I/O terminals.
5	 push the "ENTER" button after changing the frequency reference (flash Hz LED in the lower right)	Go to the frequency reference screen to change the reference when using keypad for operating. Push the ENTER key after changing the value.
6		The inverter can be operated (RUN/STOP) by the following buttons. RUN / STOP
7	Turn off the main voltage	Caution! Be sure to turn off the main voltage after stopping the inverter operation.
8	Input the main voltage again	Caution! There should be no "RUN" signal at the same time of inputting the main voltage.
9		[A0-0] Local/Remote item gets back to the default value which is [REMOTE] when the main voltage is inputted again after it is turned off. Therefore, it should be set to [LOCAL] again to use keypad operation.
10		Go back to the frequency reference screen operating by keypad. Users can check that the old value is stored. The reference can be changed to the desired value again.
11		If [LOCAL] is set at [A0-0] Local/Remote item in step 9, the inverter can be operated (RUN/STOP) by RUN / STOP keys.

6

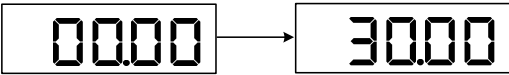
※ Continuous Use of Keypad.

	STEPS	DESCRIPTION
1	Input the main voltage	Caution! There should be no "RUN" signal at the same time of inputting the main voltage.
2		This is the initial screen when the inverter is ready to operate after it is turned on. ([A1] Drive Monitor Page)
3		Move to [A2-03] Parameter Edit Page. Then, set the followings: P03.00 (RUN/STOP Method) = [1]OPERATOR P03.01 (Reference Method) = [1]OPERATOR
4		Move to [A0]Operation Menu Page.
5	 <p>push the "ENTER" button after changing the frequency reference(flash Hz LED in the lower right)</p>	Go to the frequency reference screen to change the reference when using keypad for operating. Push the ENTER key after changing the value.
6		The inverter can be operated (RUN/STOP) by the following buttons. RUN / STOP
7	Turn off the main voltage	Caution! Be sure to turn off the main voltage after stopping the inverter operation.
8	Input the main voltage again	Caution! There should be no "RUN" signal at the same time of inputting the main voltage.
9		The inverter can be operated (RUN/STOP) by the following buttons. RUN / STOP . At this time, the frequency reference is the value that was set in step 5. If it needs to be changed again, go back to the step 5. Then, follow the description.

6.2.2 Main Menu Page[1] Drive Monitor

In [A0] Drive Monitor Page, it allows to monitor the operation status of inverter, I/O reference status and setting information. Refer to Figure 6.2-3 for the setting instruction and usage of KEYPAD.

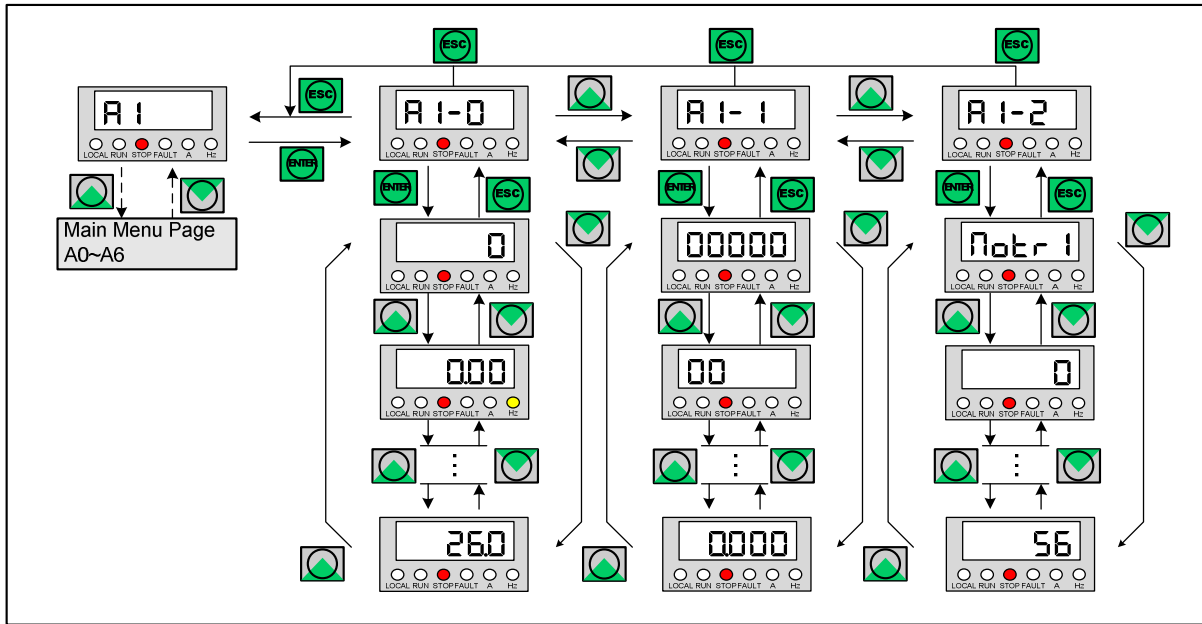

Figure 6.2-3 "[A1] Drive Monitor" Menu Page

A1 Drive Monitor Menu Page				
Menu	Item	LED Display	Unit	Description
[0] Operation Status	[0] Motor Speed	0	rpm	Indication of motor speed
	[1] Output Frequency	000	Hz	Indication of output frequency
	[2] DC Link Voltage	0000	Vdc	Indication of DC Link Voltage
	[3] Motor Current	00	Arms	Indication of Motor Current
	[4] Output Voltage	00	Vrms	Indication of Output Voltage
	[5] Actual Torque	000	Nm	Indication of motor Torque
	[6] Torque Current	00	A	Indication of Torque current
	[7] Flux Current	000	A	Indication of Flux current
	[8] Input Power	00	kW	Indication of Input Power(from inverter)
	[9] Output Power	000	kW	Indication of mechanical output of motor
	[10] PID Reference	00		
	[11] PID Feedback	000		
	[12] PID Error	00		
	[13] Temperature	300	°C	Indication of temperature of the power module or heatsink inside the inverter.
[14] Acc Run Time_10hr	0	10hr	Operation time in 10 hours unit.	

<Next>

<Continued>

A1 Drive Monitor Menu Page				
Sub Menu	Item	LED Display	Unit	Description
[1] Terminal I/O	[0] Digital Input	00000		Indication of status for digital input. Refer to Figure 6.2-3(a)
	[1] Digital Output	00		Indication of status for digital output. Refer to Figure 6.2-3(b)
	[2] Analog Input 1	0000	V or mA	Indication of Analog Voltage(0[-10]~10V) or Analog Current (0[4]~20mA) for AI 1 port.
[2] Drive Information	[0] Motor Selection	Motor 1		Indication of selected motor in case of multi-motor control.
	[1] Control Method	0		Indication of Motor Control Method
	[2] RUN/STOP Source	0		Indication of the source where start/stop signal for the motor comes from. (KEYPAD, I/O Terminal, communication, etc.)
	[3] Reference Method	0		Indication of the source where frequency, speed and torque Reference are supplied from (KEYPAD, I/O Terminal, communication, etc.)
	[4] Drive Power	37	kW	Indication of the inverter rated power
	[5] Drive Voltage	400	V	Indication of the inverter Voltage Range Ex) 400 : 400V class inverter
	[6] Option Card	0		Indication of option card number (0: not installed / over 1 : number of the installed option card)
	[7] Software Version	129		Indication of the inverter program version
	[8] Software Option	61		Indication of the inverter program version

6

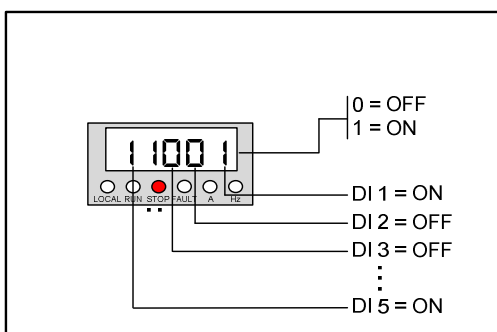

Figure 6.2-3(a) Status of Digital input

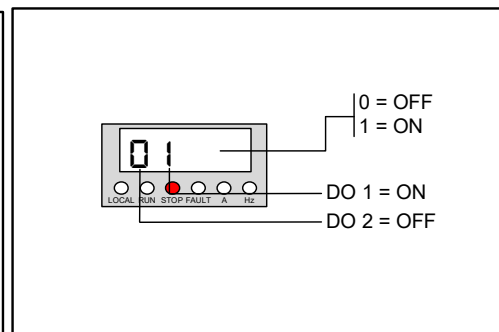

Figure 6.2-3(b) Status of Digital output

6.2.3 Main Menu Page[2] Parameter Edit

In [A2] Parameter Edit Page, the parameter can be set depending on the motor spec., control method and external I/O reference method, etc. The user-prohibited parameter groups or items would be skipped without any indication.

After finishing the set-up for parameters, move to the indicating screen that shows “Main Menu Page” so the changed parameters would be saved and remained intact after the inverter is turned off. If a user turns off the main power at the parameter item indicating screen, parameters will be returned to the old data when the main power is back again.

Refer to Figure 6.2-4 for KEYPAD usage and setting instruction in [A2] Parameter Edit.

6

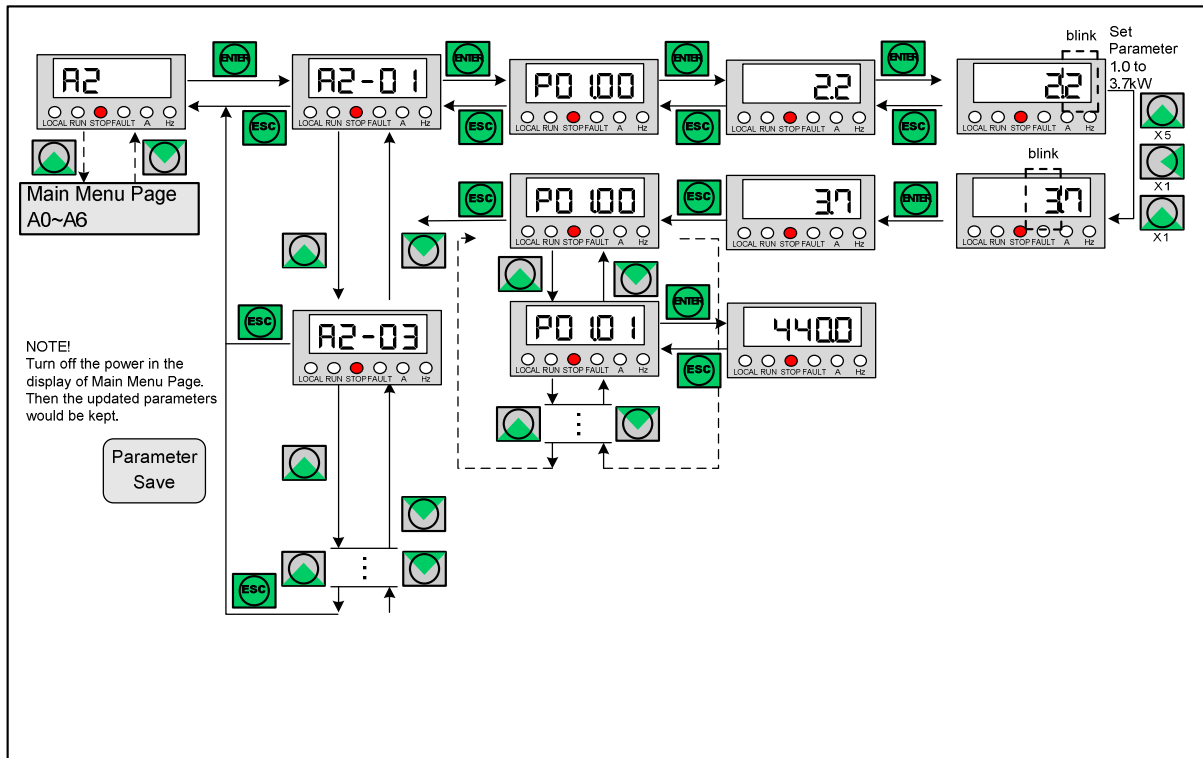

Figure 6.2-4 “A2 Parameter” Menu Page

6.2.4 Main Menu Page[A3] Auto Tuning

[A3] Auto Tuning Page, users can use the Auto Tuning to find parameter value of the motor and gain value of the torque control loop that are not easy to set for users.

The usage of Auto Tuning is restricted by the setting of Control Method(P01.06), installed environment and condition of motor, so use it carefully. Even if the moto is not running, the output of inverter is still generation so please be more careful. Carry out the process after certainly knowing the method of Auto Tuning first at chapter 7.3.

Refer to Figure 6.2-5 for KEYPAD usage and the setting instruction for Auto Tuning.

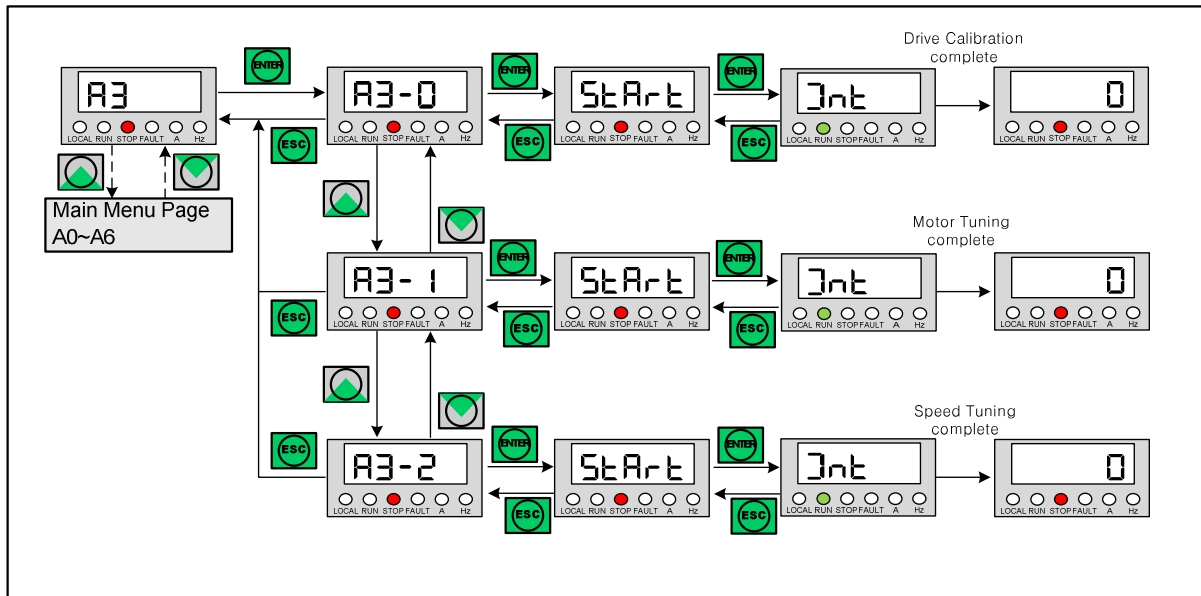

Figure 6.2-5 "[A3] Auto Tuning" Menu Page

No	A3 Auto Tuning	LED Display	Description
[0]	Drive Calibration	A3-0	Adjust automatically sensor-related parameters of Drive after initializing parameters or changing the switching frequency of the inverter.
[1]	Motor Tuning	A3-1	Recognize the parameter value of motor and set the related parameters automatically.
[2]	Speed Tuning	A3-2	Set the related parameter automatically after finding the gain value of speed control loop. Carry out this motor tuning when using S/L Vector Speed Control or Vector Speed Control. No need to use this when using V/F Frequency Control or V/F Speed control method. It cannot be carried out if the motor is mechanically locked.

6.2.5 Main Menu Page[4] Fault Record

[A4] Fault Record Page, users can monitor the number of Faults, Fault code and operation status when it occurs. Total 9 Faults can be saved from Record (1) to the latest occurred Fault. If Faults are occurred more than 9, the oldest Fault record is erased. Refer to Figure 6.2-6 for KEYPAD usage and the setting instruction.

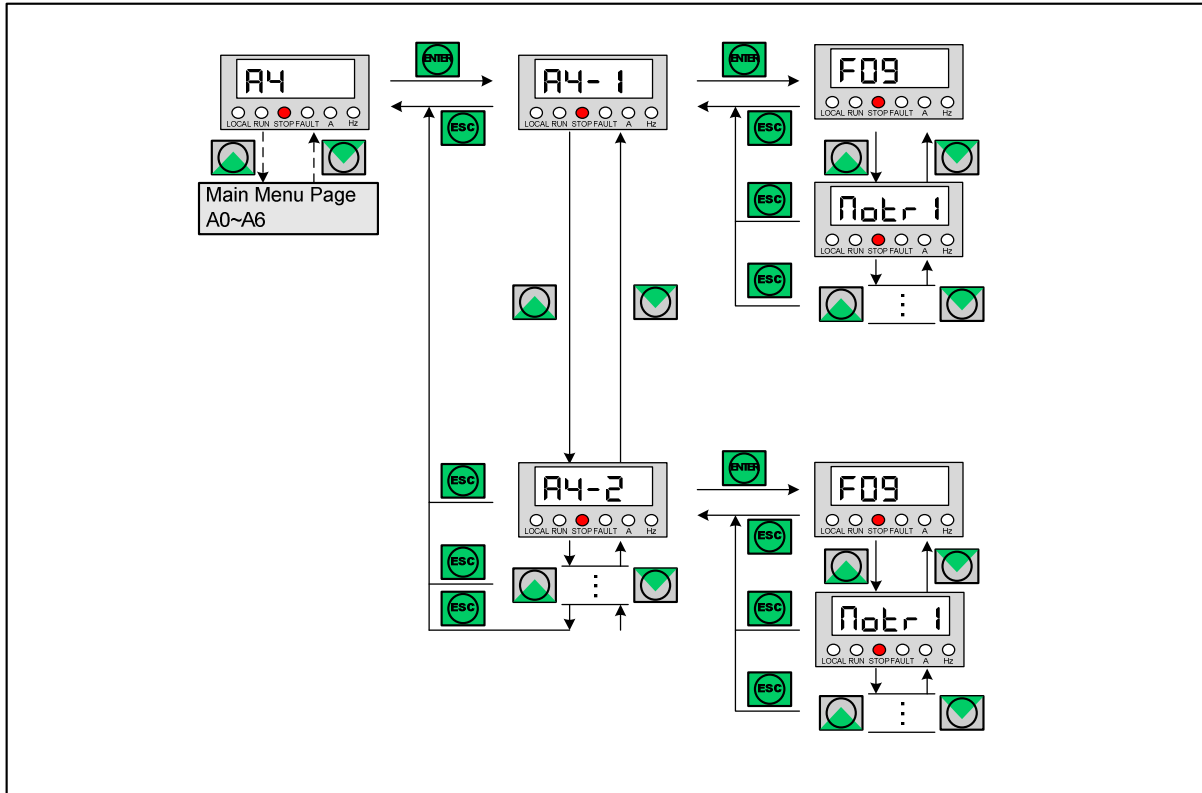

Figure 6.2-6 “[A4] Fault Record” Menu Page

A4 Fault Record	LED Display	No	Unit	Description
Total = x (x: Total occurred Faults number) Record (y) y: occurred order y=1~9 1 = the latest occurred Fault	F00	[y.1] Fault Code		Fault details (Refer to the Fault Code table)
	Motor 1	[y.2] Motor Selection		Indication of the used motor.
	□	[y.3] Control Method		Indication of control method when Faults occur
	□	[y.4] Speed command	rpm	Indication of speed command when Faults occur
	□	[y.5] Motor Speed	rpm	Indication of Motor Speed when Faults occur
	0000	[y.6] Frequency	Hz	Indication of output frequency when Faults occur
	000	[y.7] Temperature	°C	Indication of temperature of Power module and heatsink when Faults occur.
	000	[y.8] Actual Torque	Nm	Indication of output torque when Faults occur
	0000	[y.9] DC Link Voltage	Vdc	Indication of DC link voltage when Faults occur
	00	[y.10] Motor Current	Arms	Indication of Motor Current when Faults occur
	0000	[y.11] Motor Voltage	Vrms	Indication of Motor Voltage when Faults occur

6.2.6 Main Menu Page[5] Initialize

In [A5] Initialize Page, users can remove the recorded Fault list, reset the system of inverter drive and return to the default parameter values. (available above access level L1)
Refer to Figure 6.2-7 for KEYPAD usage and the setting instruction.

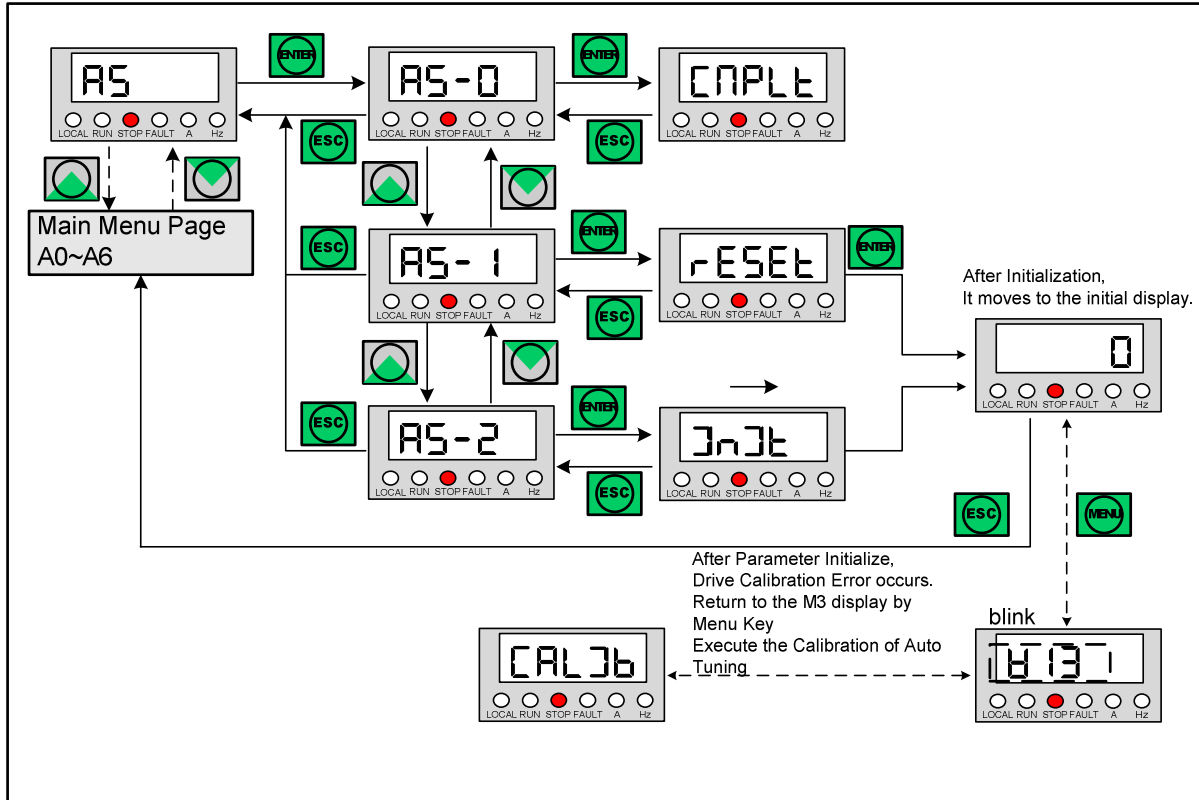

Figure 6.2-7 "[A5] Initialize" Menu Page

No	A5 Initialize	LED Display	Description
[0]	Clear Fault List	A5-0	remove the all recorded fault details
[1]	System Reset	A5-1	reset the system of the inverter (Same effect to give the main power back again after turn off the inverter.)
[2]	Parameter	A5-2	return all the parameters to the default value If Drive Calibration Warning (W14) occurs, this carries out the [0]Drive Calibration of Main Menu Page[3] Auto Tuning.

6.2.7 Main Menu Page[6] Password

In [A6] Password Page, users can check what the Access Level of the current parameter can be edited. If a user wants to change the inverter parameters for more professional level, the user must be certified for higher level access. Certifying the higher level access can be done at "[1] Admission" with the relevant password for each level. Then, the parameters of the higher level can be accessed. It is recommended to use Access level from 0 to 1 for normal users (L[0] ~ L[1]). If users want higher level, please contact the head office. If users are certified higher than L[1], it will be returned to L[0] automatically after 1 hour passes. Refer to Figure 6.2-8 for KEYPAD usage and the setting instruction.

6

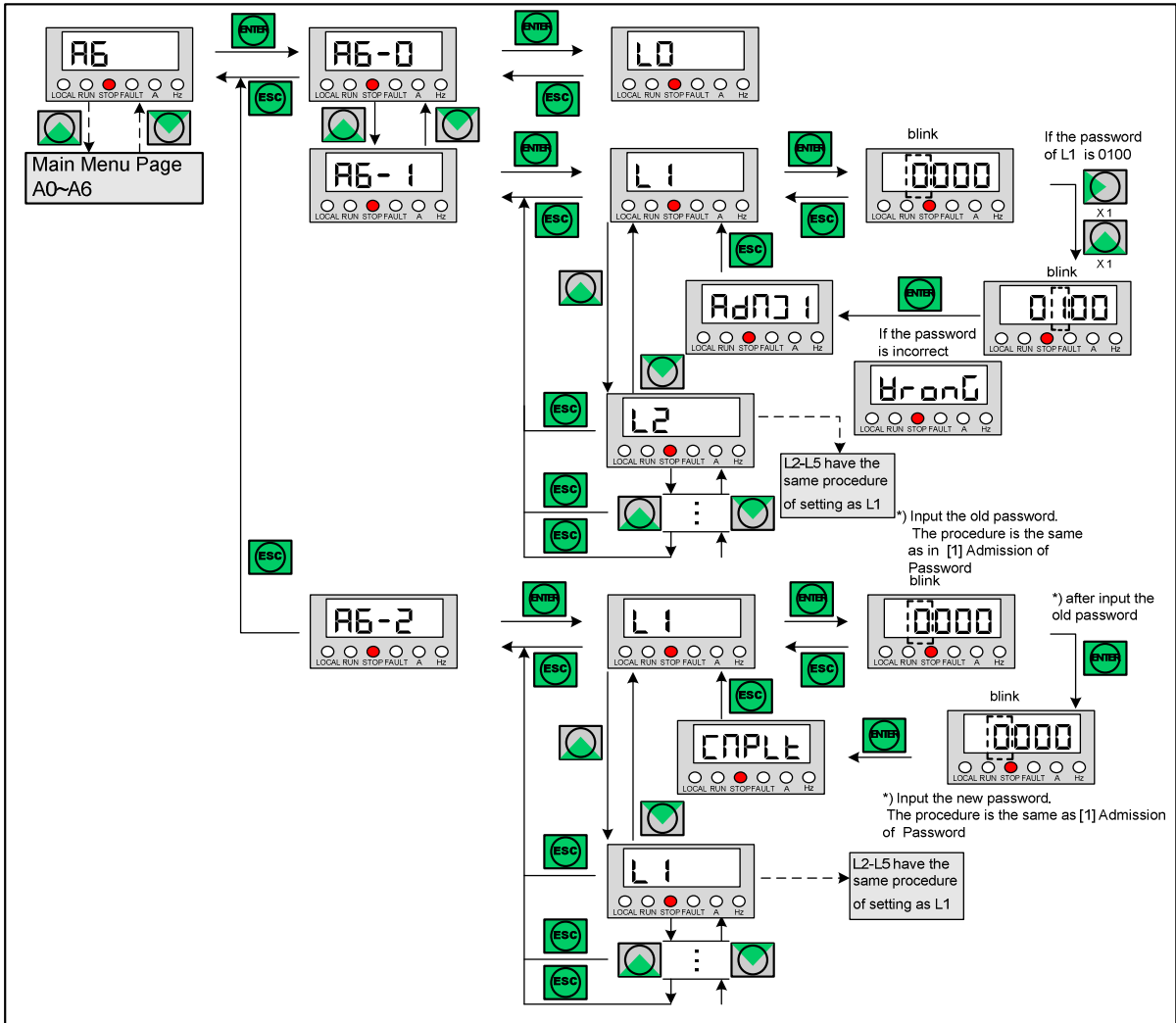

Figure 6.2-8 "[A6] Password" Menu Page

No	A6 Password	LED Display	Description
[0]	Access Level	A6-0	Indication of certified Access level
[1]	Admission	A6-1	L[1] : Password 0 0 0 0
			L[2] ~ L[5] : Contact the head office
[2]	Password Change	A6-2	Change the password for the certified level (users can directly change the password)

6.2.8 Use of MENU KEY (Check of Inverter status)

Use the **MENU** key to display the current status of the inverter.

Status messages are displayed in two digits, and see Table 6.2-9 below for a description of status messages.

LED Display	Status Message	Description
03	Ready	Ready: stand-by
10	Running	Status during operation (Displayed when the current speed is 0[rpm] or 0[Hz])
11	FWD Running	Status during forward operation
12	FWD Stopping	Status during forward stop
13	REV Running	Status during reverse operation
14	REV Stopping	Status during reverse stop
06	Warning	Warning status
08	Auto Tuning	Auto Tuning in progress status

Table 6.2-9 Status messages of inverter

7. Operation

7.1	Inverter Turning-on Procedure	7-1
7.2	Inverter Operation Procedure (set up for Control Method)	7-1
7.2.1	Open Loop Control Procedure	7-2
7.3	Auto-Tuning Procedure	7-3
7.3.1	Checking Points before Auto Tuning	7-3
7.3.2	Auto Tuning Operation & Completion	7-4
7.4	Basic Open Loop Control Operation Procedure	7-5
7.4.1	Basic Design	7-5
7.4.2	Motor Specification & Open Loop Control Method Setting	7-6
7.4.3	Speed or Frequency Reference & Digital Input Setting	7-9
7.4.4	Digital and Analogue Output Setting	7-10
7.4.5	Operating Pattern Setting	7-11
7.4.6	Brake Control Parameter Setting Using Digital Output	7-15

7. Operation

7.1 Inverter Turning-on Procedure

In order to connect a main voltage to an inverter, as Figure 7.1-1, check the main voltage to connect the inverter, motor, DBR(Dynamic Brake Resister), and etc. If a brake is connected to the motor, the brake should be opened forcedly or a device that can control the brake to be opened or closed.

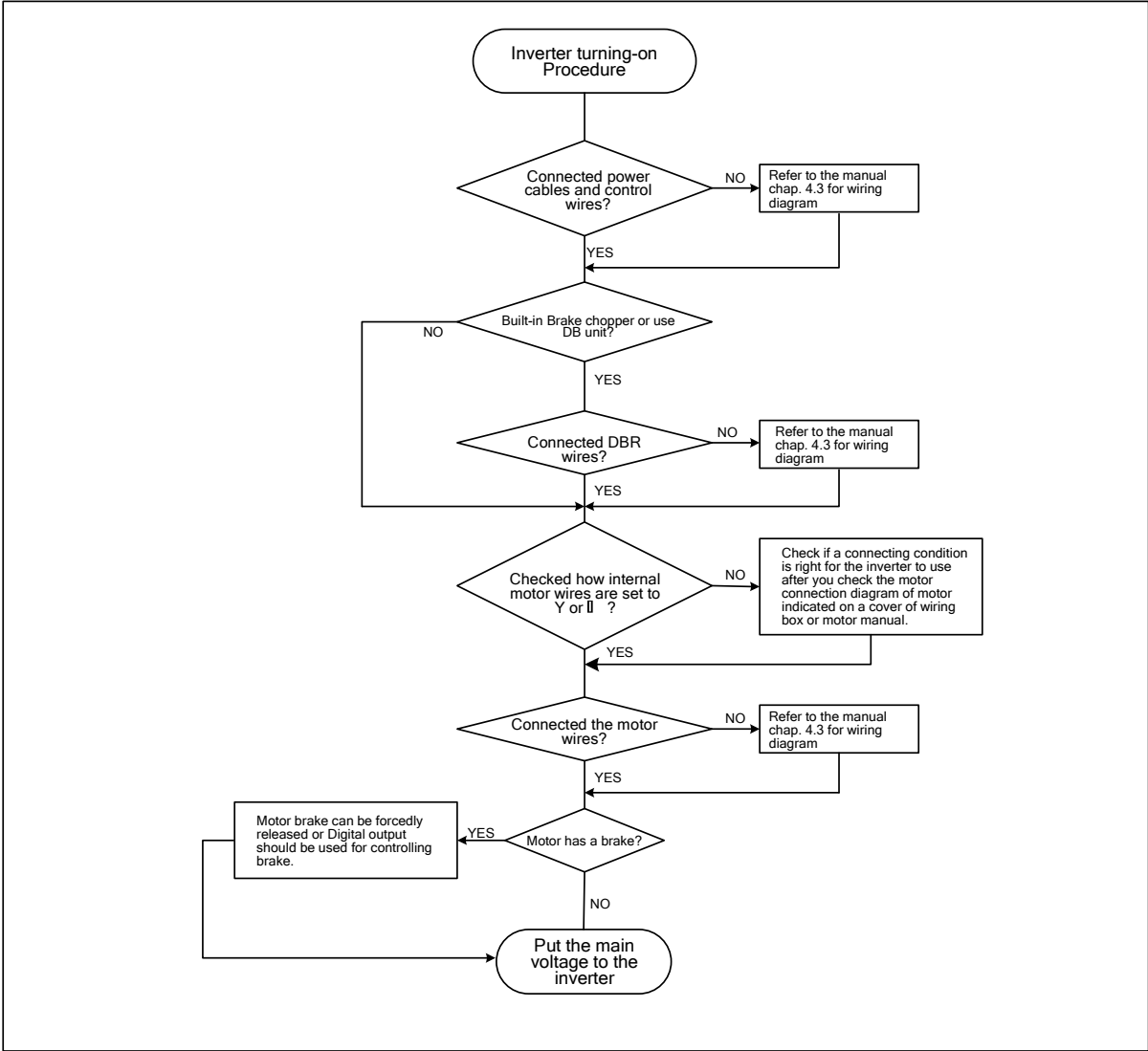

Figure 7.1-1 The processing flowchart of turning on the inverter

7.2 Inverter Operation Procedure (setup for the control method)

If you finish with preparation for connecting the main voltage to the inverter, you can operate the motor after setting a control method as Figure 7.2-1. There are control methods of **SOHO NC inverter**, which are V/F Frequency Control, **Open Loop Control** of S/L Vector Speed Control. Except for the V/F Frequency control method, the rest of control methods will work only when you operate Auto Tuning. Refer to the chapter 7.3 for Auto Tuning.

7.2.1 Open Loop Control Procedure

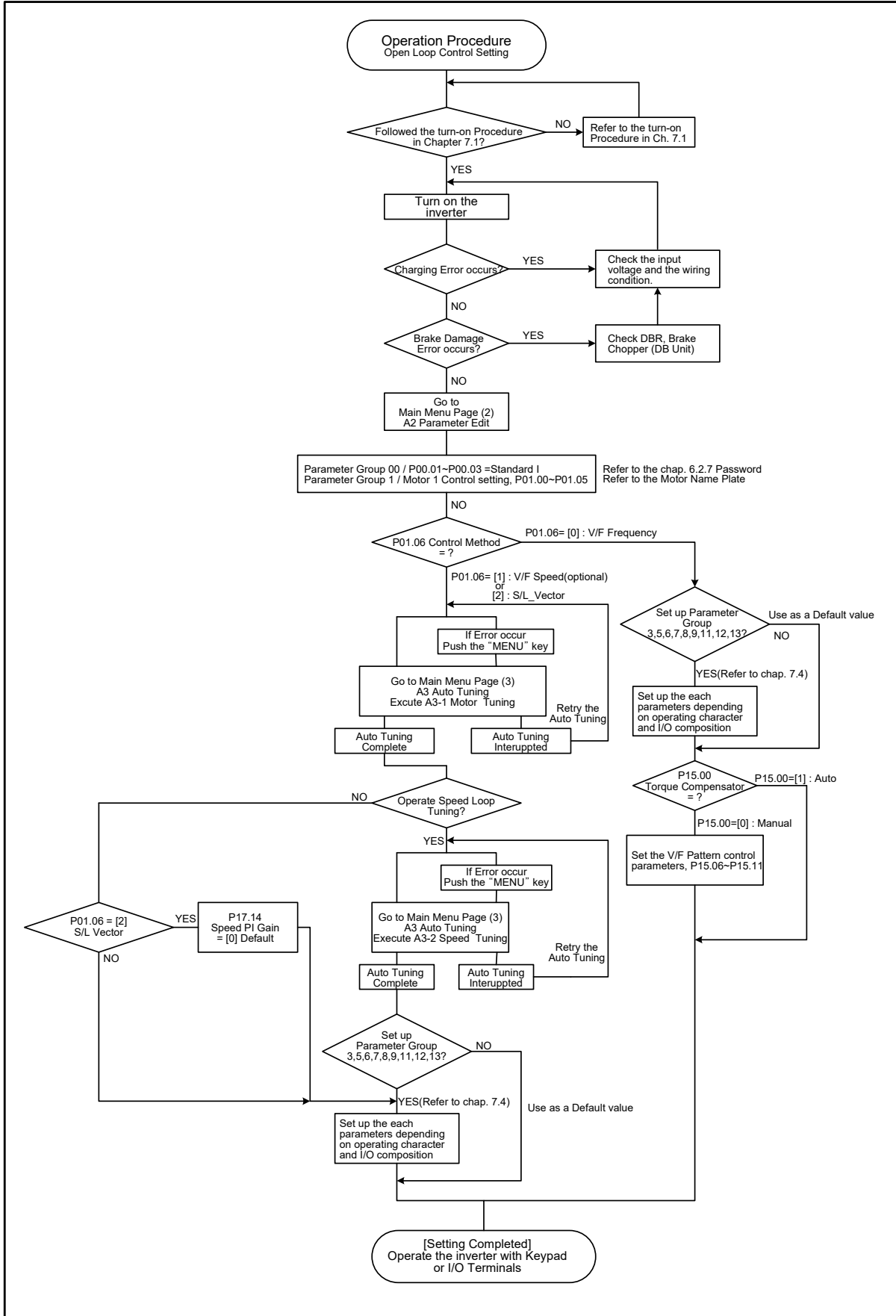

Figure 7.2-1 The processing flowchart of Open Loop Control operation

7.3 Auto-Tuning Procedure

7.3.1 Checking Point before Auto Tuning

Step	Checklist
<p>Check 1</p>	<p>Is a motor Shaft connected to the other machine?</p> <p>In a process of Auto Tuning the motor can rotate up to about 5% of the rated speed. In this case, if the motor is connected to a processing line or other machine, check out whether or not there is any effect from the motor rotation. If there is a possibility of causing a fatal problem, you need to operate Auto Tuning after you separate the motor from other device. If it is difficult to separate you need to make a condition for operation that will not cause any problem even if the motor rotates. The best condition of Auto Tuning is when there is no load of the motor and mechanical devices are connected as they are. Especially in Speed Tuning, you can get more exact result when the entire mechanical devices are connected.</p>
<p>Check 2</p>	<p>Does the motor have any load or is it connected to a Mechanical Brake?</p> <p>If the Brake is installed to the motor, it should possibly be released during the Auto-Tuning process. You can release the Brake by your hands or connect the Brake Control Circuit to the Digital Output terminal of the inverter. If the Brake can be released, check if P14.00= [0] Free. After it is released, if the load that is more than 50% of the rated load is impressed, Auto tuning may not be smooth. If you are in a situation that you have to operate Auto Tuning while the Brake is closed, you need to set up P14.00= [1] Locked. And only Motor Tuning is possible to operate, but not a Speed Tuning. If the Speed Tuning does not operate, set P17.14, P18.14, P19.19, P20.19 to 0(Default) and then use. In this case, you use the factory-setting values for a speed controller.</p>
<p>Check 3</p>	<p>Is there a big difference between the motor power and the inverter power?</p> <p>Auto Tuning may not operate well if power of the motor to connect to the inverter is too small in comparison with that of the inverter. The motor power should be at least over 1/5 of the inverter power.</p>
<p>Check 4</p>	<p>Did you input the motor specification in Parameter Group1?</p> <p>Set up the rated power, voltage, current, speed, and number of poles of the motor to the parameter items that are conformed to the Parameter Group 1. Refer to the rating plate information on the motor.</p>

7

7.3.2 Auto Tuning Operation & Completion

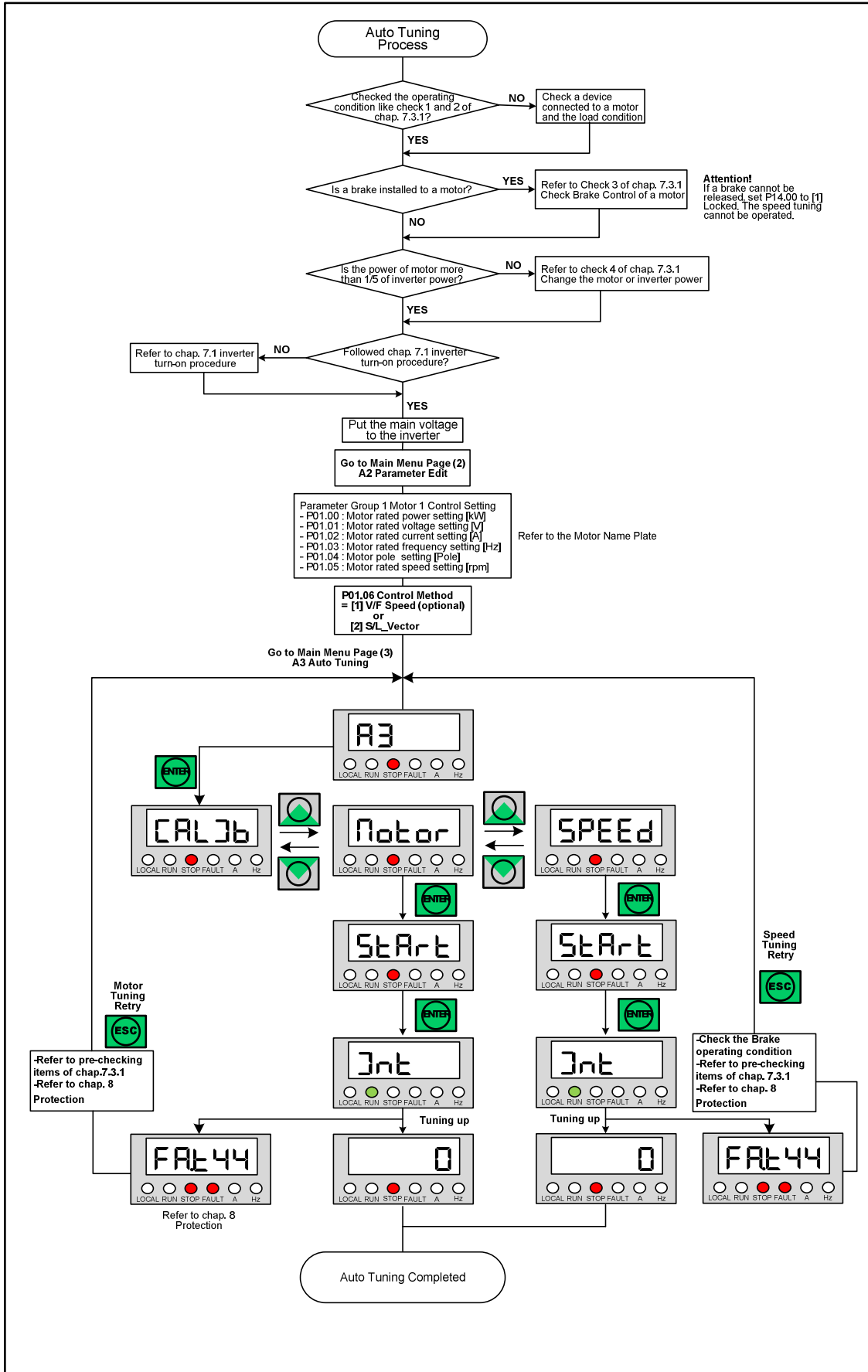

Figure 7.3-1 The processing flowchart of Auto Tuning

7.4 Basic Open Loop Control Operation Procedure

The chapter 7.4 explains the most basic application method for operating the inverter with Open Loop Control.

7.4.1 Basic Design

The following design allows you to use all the basic I/O functions when you use SOHO NC inverter. You can adjust it depending on the given condition on the field.

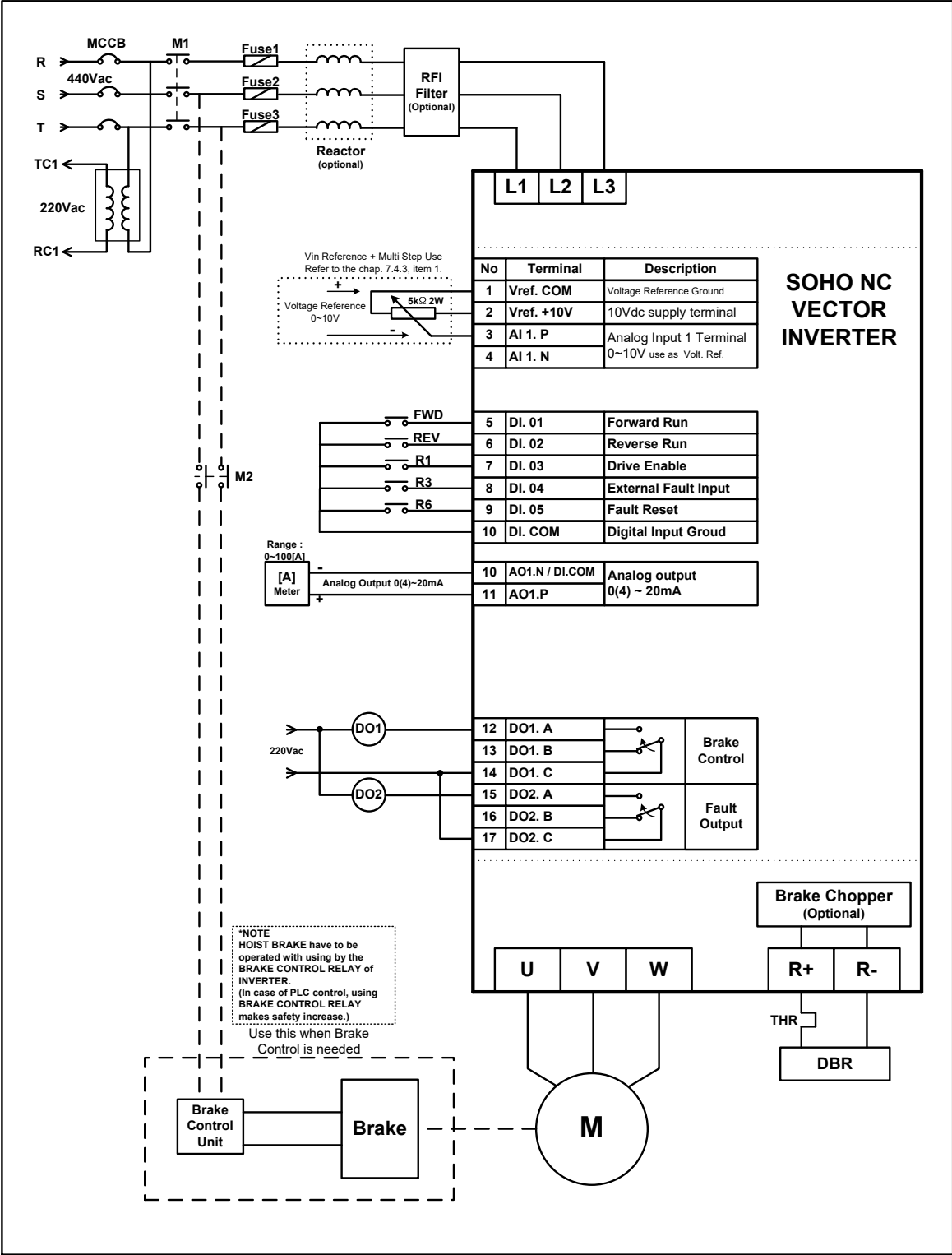

Figure 7.4-1 Basic Diagram for Inverter Use

7.4.2 Motor Specification & Open Loop Control Method Setting

This is how you set up a parameter for the motor specification and Open Loop Control method when you use the same motor specification as below.

The rated specification of the motor to be used for the inverter system					
Power	2.2 kW	Current	5.5 A	Speed	1750 rpm
Voltage	440 V	Frequency	60 Hz	Pole	4 pole

(1) Parameter setting for motor specification

Order	Parameter Group 1 : Motor 1 Control			
	Par. NO	Parameter Name	Set Value	Explanation
1	P01. 00	Motor Rated Power	2.2 kW	Rated power of motor (*) When more 2 motor are connected in parallel, the sum of rated capacity of motor is input.
2	P01. 01	Motor Rated Voltage	440 V	Rated voltage of motor
3	P01. 02	Motor Rated Current	5.5 A	Rated current of motor (*)When more 2 motor are connected in parallel, the sum of rated capacity of motor is input.
4	P01. 03	Motor Rated Frequency	60 Hz	Rated frequency of motor
5	P01. 04	Number of Poles	4 Pole	Number of poles of motor
6	P01. 05	Motor Rated Speed	1750 rpm	Rated speed of motor

(2) Motor Control Setting

④ V/F Frequency Control Setting

► Incase of using Automatic Torque Compensation (recommendable)

Order	Parameter Group 1 : Control Setup[Motor 1] : Set of control of motor1			
	Par. NO	Parameter Name	Set Value	Explanation
1	P01. 06	Control Method	[0] V/F Freq[vF-F]	V/F Frequency Control
Parameter Group 15 : V/F Control Motor 1				
2	P15. 00	Torque Compensation	[1] Auto [Auto]	Automatic Torque Compensation (recommendable)

Refer to the Speed or Frequency reference and Digital Input Setting, Chapter 7.4.3 → Page 7-9

► Refer to Figure 7.4-3 if you want to adjust the output rated voltage (V) or the rated frequency (F) of your own accord

Order	Parameter Group 15 : V/F Control [Motor 1] : Set of frequency of motor1			
	Par. NO	Parameter Name	Set Value	Explanation
1	P15. 00	Torque Compensation	[0] Manual	Users can adjust the amount of compensation
2	P15. 06	V/F Pattern	[2] User	Users can adjust the V/F curve
3	P15. 07	Zero Frequency Voltage	1.5 %	100% = 440V (P01.01 set value)
4	P15. 08	Mid. Frequency	5 Hz	Mid-point frequency
5	P15. 09	Mid. Frequency Voltage	10 %	Output voltage at mid-point frequency(P15.08) 100% = 440V (P01.01 set value)
6	P15. 10	Max. Voltage Frequency	99 %	Frequency at maximum output voltage

<Next>

<Continued>

Parameter Group 15 : V/F Control [Motor 1] : Set of frequency of motor1				
Order	Par. NO	Parameter Name	Set Value	Explanation
7	P15. 11	Max. Output Voltage	100 %	Output Voltage at mid-point frequency(P15.10) 100% = 440V (P01.01 set value)

Refer to the Speed or Frequency reference and Digital Input Setting, Chapter 7.4.3 → Page 7-9

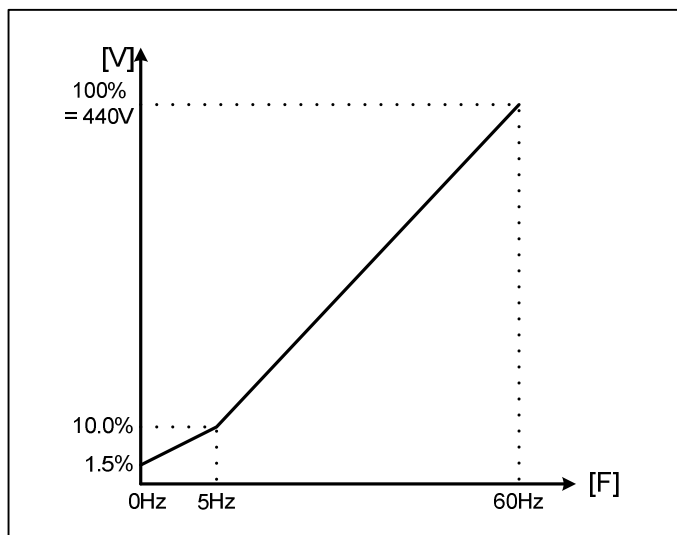

Figure 7.4-3 V/F pattern user setting example

7

② V/F Speed Control Setting

Parameter Group 1 : Control Setup[Motor 1] : Set of Control of motor1				
Order	Par. NO	Parameter Name	Set Value	Explanation
1	P01. 06	Control Method	[1] V/F Freq. Ctrl	V/F Speed Control
Parameter Group 14 : Auto Tuning Configuration : Auto tuning set				
2	P14. 00	Motor Tuning Condition	[0] Free	When a Brake is not installed to a motor, or can be released during Auto Tuning. (caution: motor should be on no load)
			[1] Lock	When a Brake is installed to a motor, and it cannot be released during Auto Tuning
Main Menu Page[3] Auto Tuning				
3	A3-1	"Motor Tuning: operation (refer to chapter 7.3)		

Refer to the Speed or Frequency reference and Digital Input Setting, Chapter 7.4.3 → Page 7-9

③ S/L Vector Control Setting – Sensroless Vector Control

► In case that a Brake is not installed to a motor or can be released during Auto Tuning

Parameter Group 1 : Control Setup[Motor 1] : Set of Control of motor1				
Order	Par. NO	Parameter Name	Set Value	Explanation
1	P01. 06	Control Method	[2] S/L Vector Ctrl	Sensor less Speed Control

<Next>

<Continued>

Parameter Group 14 : Auto Tuning Configuration : Auto tuning set				
Order	Par. NO	Parameter Name	Set Value	Explanation
2	P14. 00	Motor Tuning Condition	[0] Free	No Stall
Parameter Group 17 : Sensor less Vector Control				
3	P17. 14	Speed Control PI Gain	[1] Auto	Speed control PI Gain Auto Tuning
Main Menu Page[3] Auto Tuning				
4	A3-1	"Motor Tuning" (refer to chapter 7.3)		
5	A3-2	"Speed Tuning" (refer to chapter 7.3)		

Refer to the Speed or Frequency reference and Digital Input Setting, Chapter 7.4.3 → Page 7-9

► In case that motor brake is installed and can not be opened

("A3 Auto Tuning" = [2]Speed Tuning is unavailable)

7

Parameter Group 1 : Control Setup[Motor 1] : Set of Control of motor1				
Order	Par. NO	Parameter Name	Set Value	Explanation
1	P01. 06	Control Method	[2] S/L Vector Ctrl	Sensor less Speed Control
Parameter Group 14 : Auto Tuning Configuration : Auto tuning set				
2	P14. 00	Motor Tuning Condition	[1] Lock	Stall
Main Menu Page[3] Auto Tuning				
3	A3-1	"Motor Tuning" (Refer to chapter 7.3)		
Parameter Group 17 : Sensor less Vector Control				
4	P17. 14	Speed Control PI Gain	[0] Default	The value of PI Gain Speed is the same as that of factory shipping. P17.18 and P17.19 are adjustable.

Refer to the Speed or Frequency reference and Digital Input Setting, Chapter 7.4.3 → Page 7-9

7.4.3 Speed or Frequency Reference & Digital Input Setting

This is a parameter setting when you configure Reference and I/O with Analog Input and Digital Input as the Figure 7.4-1. When there is no Multi-Step Digital Input, analog Inputs are automatically recognized as speed or frequency references. The Multi-Step references are automatically recognized if there is more than one Digital Input related to Multi-Step signals.

(1) Parameter Setting for Speed or Frequency Reference + Multi Step (0[-10] ~10V)

Order	Parameter Group 3 : Reference Setup 1 : Set of speed and frequency reference of motor1			
	Par. NO	Parameter Name	Set Value	Explanation
1	P03. 00	RUN/STOP Method	[0] Terminal	RUN/STOP with DI.01 & DI.02
2	P03. 01	Reference Method	[0] Terminal	Use Analog input and Multi Step for speed or frequency reference
	Parameter Group 6 : Analog Input Setup : Set of analogue input			
3	P06. 00	Analog Reference Source	[1] AI 1	Use only r1 for Analog Input (Input analogue signal to the #3 and #4 terminals)
4	P06. 01	Analog Input 1 Function	[1] AI 1	Use Analog Input 1.
5	P06. 02	Analog Input 1 Type	[0] 0~10	Use Voltage Input(0~10V) for Speed Reference
	Parameter Group 8 : Digital Input Setup : Digital input setting			
6	P08. 00	RUN/STOP	[0] 0	Set Digital Inputs for RUN/STOP (Connect to #5 and #6 terminals.)
7	P08. 01	DI.03 Function	[1] 1	Set DI.03 Function to "Drive Enable" (Connect to #7 terminal.)
8	P08. 02	DI.04 Function	[10] 10	Set DI.04 Function to "External Fault" (A contact) (Connect to #8 terminal.)
9	P08. 03	DI.05 Function	[6] 6	Set DI.05 Function to "Fault Reset" (Connect to #9 terminal.)

Refer to Digital & Analog Output Setting, the Chapter 7.4.4 → Page 7-10

(2) Parameter Setting for Current (0[4]~20mA) Input Reference + Multi Step

Order	Parameter Group 3 : Reference Setup 1 : Set of speed and frequency reference of motor1			
	Par. NO	Parameter Name	Set Value	Explanation
1	P03. 00	RUN/STOP Method	[0] Terminal	RUN/STOP with DI.01 and DI.02
2	P03. 01	Ramp Function Input Source	[0] Terminal	Use Analog input and Multi Step for speed or frequency reference
Parameter Group 6 : Analog Input Setup : Set of analogue input				
3	P06. 00	Analog Reference Source	[1] AI 1	Use only r1 for Analog Input (Connect to #3 and #4 terminals.)
4	P06. 01	Analog Input 1 Function	[1] AI 1	Use Analog Input 1 for r1
5	P06. 02	Analog Input 1 Type	[2] 4~20	Use Current Input 4~20mA
			[3] 0~20	Use Current Input 0~20mA
Parameter Group 8 : Digital Input Setup : Set of digital input				
6	P08. 00	RUN/STOP	[0] 0	Use Digital Input for RUN/STOP (Connect to #5 and #6 terminals.)
7	P08. 01	DI.03 Function	[1] 1	Set DI.03 Function to Drive Enable (Connect to #7 terminal.)
8	P08. 02	DI.04 Function	[10] 10	Set DI.04 Function to "External Fault (A contact)" (Connect to #8 terminal.)
9	P08. 03	DI.05 Function	[6] 6	Set DI.05 Function to "Fault Reset" (Connect to #9 terminal.)

Refer to Digital & Analog Output Setting, the Chapter 7.4.4→↓below

7.4.4 Digital and Analog Output Setting

This is a parameter setting for configuring with Digital Output as Figure 7.4-1 Basic Design.

Order	Parameter Group 12 : Digital Output Setup : Set of digital input			
4	P12. 00	DO 1 Function	[4] 4	Set Digital Output Function to Magnetic Brake of Motor. (When you use Motor Brake Control, refer to the Chapter 7.4.6 Brake Control Setting) (Connect to #12, #13, and #14 terminals.)
5	P12. 01	DO 2 Function	[2] 2	When Fault occurs, set Digital Output Function to work (A contact) (Connect to #15, #16, and #17 terminals.)

Refer to the Operation Pattern Setting, the Chapter 7.4.5 → Page 7-11

7.4.5 Operation Pattern Setting

It explains parameter settings when you set the Operation Pattern as Figure 7.4-4 and 7.4-5. The Figure 7.4-1 shows the basic input method.

(1) In case that you use V/F Frequency and V/F Speed Control

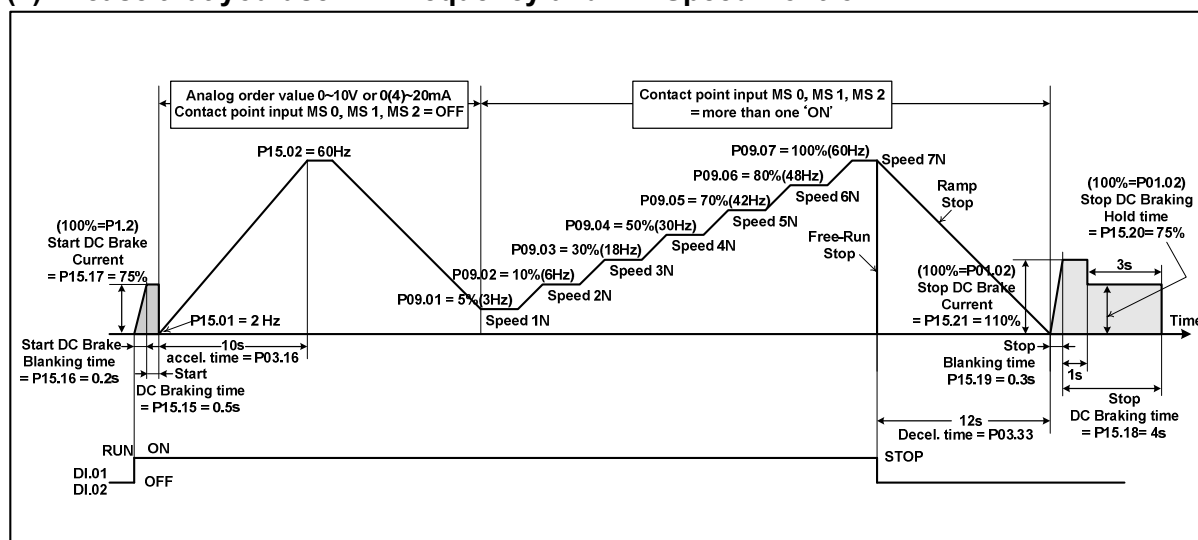

Figure 7.4-4 Operation Pattern Setting of "V/F Frequency control" and "V/F Speed Control"

① Reference Setup

Parameter Group 3 : Reference Setup 1				
Order	Par. NO	Parameter Name	Set Value	Explanation
1	P03. 03	STOP Mode	[0] Ramp	When Run-Input signal is turned OFF, inverter stops after Decel Time
			[1] Free	When Run-Input Signal is turned OFF, Inverter output is also turned OFF immediately.
			[2] Mixed STOP	When Run-input signal is turned off, the inverter output is turned off and stopped automatically after deceleration to speed set on P03.06.
2	P03. 09	Accel.Switching Ref[1-2]	Initial value=100%	100% = Rated Speed (P01.05)or Rated Frequency(P01.03) of Motor
3	P03. 16	Acceleration Time I. 1	10s	It is the accelerated time from 0 to the time that is set on P03.26.
4	P03. 26	Decel.Switching Ref[1-2]	Initial value=100%	100% = Rated Speed (P01.05)or Rated Frequency(P01.03) of Motor
5	P03. 33	Deceleration Time I. 1	12s	It is the decelerated time from the time that is set on P03.26.

② Multi Step Reference Setting

Order	Parameter Group 9 : Multi-Step Reference [Motor1] (100% = Rated Speed or Rated Frequency of Motor)			
	Par. NO	Parameter Name	Set Value	Explanation
1	P09. 01	Multi Step 1 Reference	5%	60Hz X 5% = 3Hz
2	P09. 02	Multi Step 2 Reference	10%	60Hz X 10% = 6Hz
3	P09. 03	Multi Step 3 Reference	30%	60Hz X 30% = 18Hz
4	P09. 04	Multi Step 4 Reference	50%	60Hz X 50% = 30Hz
5	P09. 05	Multi Step 5 Reference	70%	60Hz X 70% = 42Hz
6	P09. 06	Multi Step 6 Reference	80%	60Hz X 80% = 48Hz
7	P09. 07	Multi Step 7 Reference	100%	60Hz X 100% = 60Hz

③ Parameter Setting for V/F Frequency or V/F Speed Control

7

Order	Parameter Group 15 : V/F Control [Motor 1] : Set of frequency control of motor1			
	Par. NO	Parameter Name	Set Value	Explanation
1	P15. 01	Minimum Frequency	2 Hz	Set up for Minimum Output Frequency
2	P15. 02	Maximum Frequency	60 Hz	Set up for Maximum Output Frequency
3	P15. 15	Start DC Brake Time	0.5s	Operating time of DC Brake while running
4	P15. 16	Start DC Brake Blanking Time	0.2s	When starting, Accel time for DC Brake current
5	P15. 17	Start DC Brake Current	75%	When starting, DC Brake current
6	P15. 18	Stop DC Brake Time	4s	Operating time of DC Brake while stopping. The sum of occurring time of P15.20 and P15.21(1S).
7	P15. 19	Stop DC Brake Blanking Time	0.3s	Ramp time increases up to the amount of current of DC brake (P15.21) when motor stops.
8	P15. 20	Stop DC Brake Hold Current	75%	The amounts of current of DC brake after DC brake(P15.21) current for 1sec when motor stops.
9	P15. 21	Stop DC Brake Current	110%	The amounts of current of DC brake when motor stops. (100%=P01.02)

<Inverter Setting completed!> *When you use the Brake Control of motor, go to "The Chapter 7.4.6. Brake Control Setting using Digital Output" → Page 7-15

(2) When you use S/L Vector Speed Control

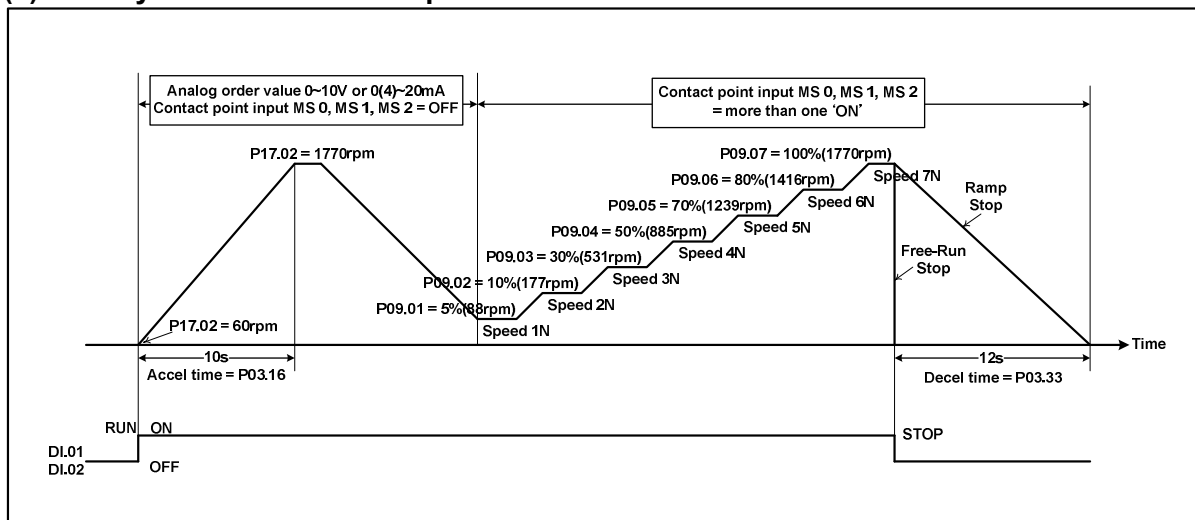

Figure 7.4-5 Operation Pattern Setting of "S/L Vector Control"

① Reference Setup Setting

Order	Parameter Group 3 : Reference Setup 1			
	Par. NO	Parameter Name	Set Value	Explanation
1	P03. 03	STOP Mode	[0] Ramp	When Run-Input signal is turned OFF, inverter stops after Decel Time
			[1] Free	When Run-Input signal is turned OFF, inverter output also is turned OFF immediately.
			[2] Mixed STOP	When Run-input signal is turned off, the inverter output is turned off and stopped automatically after deceleration to speed set on P03.06.
2	P03. 09	Accel.Switching Ref[1-2]	Initial value=100%	100% = rating frequency of motor (P01.03) or rating speed(P01.05)
3	P03. 16	Acceleration Time I. 1	10s	Accel.Time Region 1 -Refer to the explanation of parameter
4	P03. 26	Decel.Switching Ref[1-2]	Initial value=100%	100% = Rated Speed(P01.05) or Rated Frequency of Motor (P01.03)
5	P03. 33	Deceleration Time I. 1	12s	Decel.Time Region 1 -Refer to the explanation of parameter

② Multi Step Reference Setting

Parameter Group 9 : Multi Step Reference (100% = Rated Speed or Rated Frequency of Motor)				
Order	Par. NO	Parameter Name	Set Value	Explanation
1	P09. 01	Multi Step 1 Reference	5%	1770rpm X 5% = 88rpm
2	P09. 02	Multi Step 2 Reference	10%	1770rpm X 10% = 177rpm
3	P09. 03	Multi Step 3 Reference	30%	1770rpm X 30% = 531rpm
4	P09. 04	Multi Step 4 Reference	50%	1770rpm X 50% = 885rpm
5	P09. 05	Multi Step 5 Reference	70%	1770rpm X 70% = 1239rpm
6	P09. 06	Multi Step 6 Reference	80%	1770rpm X 80% = 1416rpm
7	P09. 07	Multi Step 7 Reference	100%	1770rpm X 100% = 1770rpm
8	P09. 16	Unit Selection	[0] PErC	The unit of speed is %

③ Operation Pattern Setting for Using S/L Speed Control

7

Parameter Group 17 : Sensor less Speed Control				
Order	Par. NO	Parameter Name	Set Value	Explanation
1	P17. 01	Minimum Speed	60 rpm	Set up for minimum speed.
2	P17. 02	Maximum Speed	100%	Set up for mini speed. (100%=P01.05's set value=1770rpm)
3	P17. 03	Over Speed Limit	125%	Set speed limit. (P01.05X125%=2212rpm)

<Completed Inverter Setup!> *When you use the Brake Control of motor, go to "The Chapter 7.4.6. Brake Control Setting using Digital Output" → Page 7-15

7.4.6 Brake Control Parameter Setting Using Digital Output

This explains a parameter setting when you control the Brake that is connected to a motor as Figure 7.4-1, using Digital Output as Figure 7.4-6 and Figure 7.4-7

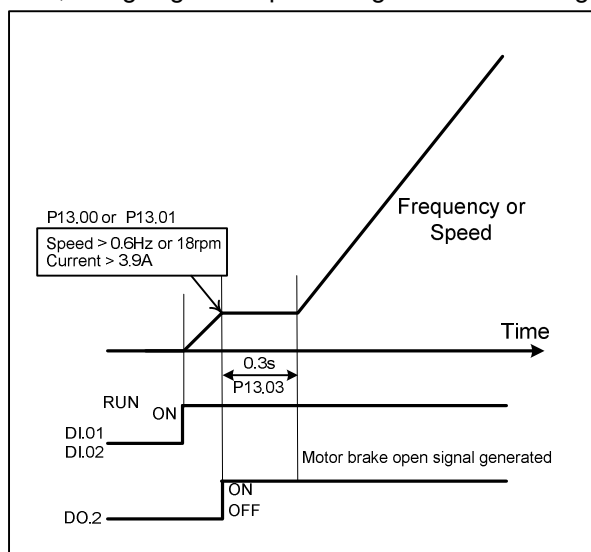

Figure 7.4-6 Mechanical Brake Releasing Signal

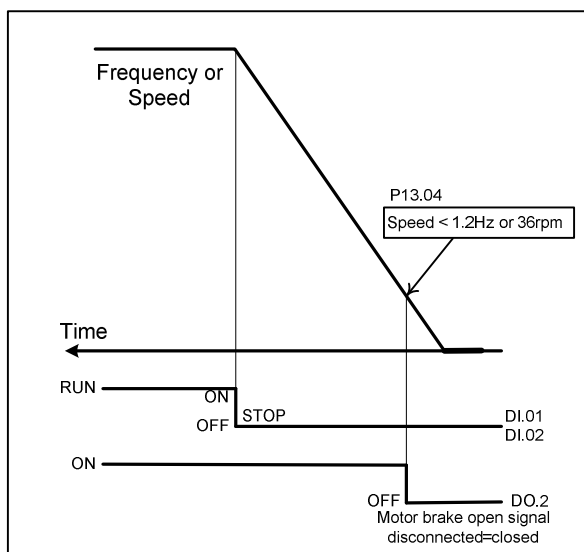

Figure 7.4-7 Mechanical Brake Closing Signal

Order	Parameter Group 12 : Digital Output Setup : Set of digital output			
	Par. NO	Parameter Name	Set Value	Explanation
1	P12. 01	DO.2 Function	[4] Brake	Set DO.2 for Brake Control
Parameter Group 13 : Magnetic Brake Control : Set of motor brake control				
2	P13. 00	M1 Locked state Up_Ref	1%	Digital Output ON for Frequency or Speed Reference
3	P13. 01	M1 Locked state Down_Ref	1%	(60Hz,1770rpm) X 1% = 0.6Hz, 18rpm
4	P13. 02	M1 Brake Open Current	10%	Current of Digital Output ON 38.9A X 10% = 3.9A After inputting operating signal, set time should be passed until set time of P13.05.
5	P13. 03	M1 Start Delay Time	0.3s	Set up for the time that passes until the Brake is completely opened after Digital Output is ON. The speed or frequency reference is maintained for the M1 Open Response Time.
6	P13. 04	M1 Brake Close Speed Set	2%	Frequency of Digital Output OFF & Speed Reference (60Hz,1770rpm) X 2% = 1.2Hz, 36rpm
7	P13. 05	M1 Brake Open Torque Build Time	0.2s	This is delay time until contact point output is turned into 'on', after inputting the operating signal. At this time, output current must be more than set value in P13.02

< Digital Output Setting for Brake Control Completed!>

8. Parameter

8.1 Parameter Table 8-1
8.2 Parameter Description 8-16

8. Parameter

8.1 Parameter table

Parameter Group 0: Program Control

Par. NO	Parameter Name LED Display	Unit	Default	Range	Access Level	Note	Ref. Page
P00.12	Initialization_ Permission_Key P00.12	[hex]	0	0 ~ 39321	1		
P00.14	Norminal_Frequency Class P00.14		1	[0] 50 Hz Class [1] 60 Hz Class	1		
P00.15	Thermal_Monitor Class P00.15		1	[0] Thermal_State_Relay [1] NTC_Thermistor	1		

Parameter Group 1: Control Setup [Motor 1] *) Default value is different depending model capacity of inverter.

Par. NO	Parameter Name LED Display	Unit	Default	Range	Access Level	Note	Ref. Page
P01.00	Rated Power P01.00	kW	0	0.1 ~ 15.0	0	0.75 kW is indicated as 0.8 kW	
P01.01	Rated Voltage P01.01	Vrms	0	150 ~ 600.0	0		
P01.02	Rated Current P01.02	Arms	0	0.1 ~ 100.0	0		
P01.03	Rated Frequency P01.03	Hz	0	5 ~ 120.0	0		
P01.04	Number of Poles P01.04	pole	0	2 ~ 8	0		
P01.05	Rated Speed P01.05	rpm	1800	0 ~ 7200	0		
P01.06	Control Method P01.06		0	[0] V/F Freq_Ctrl [1] V/F Spd_Ctrl [2] S/L Vector_Ctrl [3] Vector_Ctrl	0		
P01.07	PWM Frequency P01.07	kHz	2.5	0.8 ~ 6.0	1		
P01.09	Supply voltage P01.09	Vrms	0	150.0 ~ 600.0	0		

Parameter Group 3: Reference Setup [Motor1]

Par. NO	Parameter Name LED Display	Unit	Default	Range	Access Level	Note	Ref. Page
P03.00	RUN/STOP Method P03.00		0	[0] Terminal [1] Operator (RS 232C) [2] Synchronous_Ctrl [3] Fieldbus [4] Free Function Logic	0		
P03.01	RampFunc_Input_Src P03.01		0	[0] Terminal (Digital, Analog) [1] Operator (RS 232C) [2] Synchronous_Ctrl [3] Free Function	0		

Parameter

Par. NO	Parameter Name LED Display	Unit	Default	Range	Access Level	Note	Ref. Page
P03.02	Stop Command Detection Time P03.02	S	0.00	0.00 ~ 3.00	0		
P03.03	STOP Mode P03.03		0	[0] Ramp STOP [1] Free-Run STOP [2] Mixed STOP	0		
P03.04	STOP Hold Time P03.04	s	0.00	0.00 ~ 50.0	0		
P03.05	Output Off Hold Time P03.05	s	1.00	0.02 ~ 50.0	0		
P03.06	Mixed-mode STOP Reference P03.06	%	20.0	0.0 ~ 300.0	0		
P03.07	Acc/Dec Ramp Function P03.07		1	[0] Disabled [1] Enabled	0		
P03.08	Acceleration Time Range P03.08		0	[0] 0 ~ 300s [1] 0 ~ 3000s	0		
P03.09	Acc Switching Ref 1-2 P03.09	%	100.0	0.0 ~ 300.0	0		
P03.10	Acc Switching Ref 2-3 P03.10	%	150	0.0 ~ 300.0	0		
P03.11	Acc Switching Ref 3-4 P03.11	%	200	0.0 ~ 300.0	0		
P03.12	Acc Switching Ref 4-5 P03.12	%	225	0.0 ~ 300.0	0		
P03.13	Acc Switching Ref 5-6 P03.13	%	250	0.0 ~ 300.0	0		
P03.14	Acc Switching Ref 6-7 P03.14	%	275	0.0 ~ 300.0	0		
P03.15	Acc Switching Ref 7-8 P03.15	%	300	0.0 ~ 300.0	0		
P03.16	Acc Time I.1 P03.16	s	5	0.01 ~ 90.00	0		
P03.17	Acc Time I.2 P03.17	s	5	0.01 ~ 90.00	0		
P03.18	Acc Time I.3 P03.18	s	5	0.01 ~ 90.00	0		
P03.19	Acc Time I.4 P03.19	s	5	0.01 ~ 90.00	0		
P03.20	Acc Time I.5 P03.20	s	5	0.01 ~ 90.00	0		
P03.21	Acc Time I.6 P03.21	s	5	0.01 ~ 90.00	0		
P03.22	Acc Time I.7 P03.22	s	5	0.01 ~ 90.00	0		

Par. NO	Parameter Name LED Display	Unit	Default	Range	Access Level	Note	Ref. Page
P03.23	Acc Time I.8 P03.23	s	5	0.01 ~ 90.00	0		
P03.24	Acc Time II P03.24	s	10	0.01 ~ 90.00	0		
P03.25	Decel Time Range P03.25		0	[0] 0 ~ 300s [1] 0 ~ 3000s	0		
P03.26	Dec Switching Ref 1-2 P03.26	%	100	0.0 ~ 300.0	0		
P03.27	Dec Switching Ref 2-3 P03.27	%	150	0.0 ~ 300.0	0		
P03.28	Dec Switching Ref 3-4 P03.28	%	200	0.0 ~ 300.0	0		
P03.29	Dec Switching Ref 4-5 P03.29	%	225	0.0 ~ 300.0	0		
P03.30	Dec Switching Ref 5-6 P03.30	%	250	0.0 ~ 300.0	0		
P03.31	Dec Switching Ref 6-7 P03.31	%	275	0.0 ~ 300.0	0		
P03.32	Dec Switching Ref 7-8 P03.32	%	300	0.0 ~ 300.0	0		
P03.33	Decel Time I.1 P03.33	s	5	0.01 ~ 90.00	0		
P03.34	Decel Time I.2 P03.34	s	5	0.01 ~ 90.00	0		
P03.35	Decel Time I.3 P03.35	s	5	0.01 ~ 90.00	0		
P03.36	Decel Time I.4 P03.36	s	5	0.01 ~ 90.00	0		
P03.37	Decel Time I.5 P03.37	s	5	0.01 ~ 90.00	0		
P03.38	Decel Time I.5 P03.38	s	5	0.01 ~ 90.00	0		
P03.39	Decel Time I.5 P03.39	s	5	0.01 ~ 90.00	0		
P03.40	Decel Time I.5 P03.40	s	5	0.01 ~ 90.00	0		
P03.41	Decel Time II P03.41	s	10	0.01 ~ 90.00	0		
P03.42	Counter Deceleration Ramp Function P03.42		0	[0] Disabled [1] Enabled	0		
P03.43	Counter Deceleration Time P03.43	s	5	0.01 ~ 90.00	0		
P03.49	Emergency_STOP MODE P03.49		0	[0] Ramp STOP [1] Free-Run STOP [2] Mixed STOP	0		

Parameter

Par. NO	Parameter Name LED Display	Unit	Default	Range	Access Level	Note	Ref. Page
P03.50	Emergency_STOP Decel_Time P03.50	s	1	0.01 ~ 90.00	0		
P03.51	Continuous OP Mode P03.51		1	[0] Disabled [1] Enabled	0		
P03.52	Reverse_DIR_ Operation P03.52		1	[0] Disabled [1] Enabled	0		

Parameter Group 5: Protection] *) Default value is different depending model capacity of inverter.

Par.	Parameter Name LED Display	Unit	Default	Range	Access Level	Note	Ref. Page
P05.00	Current Limit [Motor1] P05.00	%	145.0	0.0 ~ 250.0	1		
P05.07	Max. Continuous Current P05.07	%	95.0	0 ~ 250.0	1		
P05.08	Over-Load current P05.08	%	135.0	0 ~ 250.0	1		
P05.09	Over-Load Time P05.09	s	60.00	0.00 ~ 90.00	1		
P05.10	Over-Load Fault [Action] P05.10		0	[0] STOP [1] E_STOP [2] Ctrl_OFF [3] IGNORE	0		
P05.11	Over-Current Trip [motor1] P05.11	%	220.0	0.0 ~ 350.0	2		
P05.12	Zero-sequence Current Trip P05.12	%	15.0	0.0 ~ 100.0	2		
P05.13	Over-Voltage Limiting Function P05.13		0	[0] Disabled [1] Enabled	1		
P05.14	Over Voltage Limit P05.14	V	670.0	0.0 ~ 850.0	1		
P05.15	Over Voltage trip P05.15	V	780.0	0.0 ~ 900.0	2		
P05.16	UV compensation _Fn P05.16		1	[0] Disabled [1] Enabled	1		
P05.17	UV compensation_ Voltage P05.17	V	450	0.0 ~ 700.0	1		
P05.18	Under Voltage Trip P05.18	V	360	0.0 ~ 700.0	2		

Par.	Parameter Name LED Display	Unit	Default	Range	Access Level	Note	Ref. Page
P05.19	Open Phase Protection P05.19		0	[0] Disabled [1] Enabled	0		
P05.20	Supply Frequency P05.20	Hz	60.0	0.0 ~ 100.0	0		
P05.21	Built-in Dynamic Brake P05.21		1	[0] Disabled [1] Enabled_RUN [2] En_RUN_STOP	0		
P05.23	DB Start P05.23	V	690.0	300.0 ~ 850.0	1		
P05.24	DB Full Voltage P05.24	V	710.0	300.0 ~ 850.0			
P05.25	Over-Temperature Trip P05.25		2	[0] STOP [1] E_STOP [2] CTRL_OFF [3] IGNORE [4] SPEED_DOWN	1		
P05.30	Auto Restart Count P05.30		0	0 ~ 10	1		
P05.31	Retry Delay Time P05.31	s	1.5	0.0 ~ 100.0	1		
P05.32	Auto Reset (OC) P05.32		0	[0] Disabled [1] Enabled	1		
P05.33	Auto Reset (OV) P05.33		0	[0] Disabled [1] Enabled	1		
P05.34	Auto Reset (UV) P05.34		0	[0] Disabled [1] Enabled	1		
P05.37	Out of Control Auto-Reset P05.37		0	[0] Disabled [1] Enabled	1		
P05.38	Out of Control Time P05.38	s	5.0	0.1 ~ 60.0	1		
P05.39	Out of Control Current P05.39	%	90.0	50.0 ~ 97.5	1		
P05.40	Over Temperature P05.40	deg	90.0	20.0 ~ 120.0			

Parameter Group 6: Analog Input

Par. NO	Parameter Name LED Display	Unit	Default	Range	Access Level	Note	Ref. Page
P06.00	Analog Reference Source P06.00		1	[0] Disabled [1] AI 1 [2] AI 2	0		
P06.01	AI.1 Function P06.01		1	[0] Disabled [1] AI	0		

Parameter

Par. NO	Parameter Name LED Display	Unit	Default	Range	Access Level	Note	Ref. Page
P06.02	AI.1_Type P06.02		0	[0] 0 ~ 10(5)V [1] -10 ~ 10V [2] 4 ~ 20mA [3] 0 ~ 20mA	0		
P06.04	AI.1 Filter Time Const P06.04	ms	25	1.0 ~ 900.0	0		
P06.05	AI.1 Offset P06.05	mA/ mV	0.000	-10.000 ~ 10.000	0		
P06.06	AI.1 min Voltage P06.06	V	0.00	0.00 ~ 9.00	0		
P06.07	AI.1 min Current P06.07	mA	0.00	0.00 ~ 18.00	0		
P06.08	AI.1 Minimum P06.08	%	0.0	0.0 ~ 500.0	0		
P06.09	AI.1 Max Voltage P06.09	V	10.00	1.00 ~ 10.00	0		
P06.10	AI.1 max Current P06.10	mA	20.00	2.00 ~ 20.00	0		
P06.11	AI.1 Maximum P06.11	%	100.0	0.0 ~ 500.0	0		
P06.12	AI.1 Inversion P06.12		0	[0] Disabled [1] Enabled	0		
P06.13	AI.1 Discreteness P06.13		0	[0] Disabled [1] 128 Steps [2] 64 Steps [3] 32 Steps [4] 16 Steps [5] 8 Steps	0		
P06.14	AI. 1 Dead-Zone P06.14		0	[0] Disabled [1] Enabled	0		

8

Parameter Group 8: Digital Input Setup

Par. NO	Parameter Name LED Display	Unit	Default	Range	Access Level	Note	Ref. Page
P08.00	Run/Stop Control P08.00		0	[0] 1.FWD / 2.REV [1] 1.RUN / 2.DIR	0		
P08.01	DI 3 Function P08.01		0	[0] None [1] Drive ENABLE. [2] MULTI-STEP bit.0	0		
P08.02	DI 4 Function P08.02		10	[3] MULTI-STEP bit.1 [4] MULTI-STEP bit.2 [5] MULTI-STEP bit.3			
P08.03	DI 5 Function P08.03		6	[6] Fault Reset [7] JOG			

Par. NO	Parameter Name LED Display	Unit	Default	Range	Access Level	Note	Ref. Page
				[8] AI_REF_ACTIVE [9] AI_LOCAL/REMOTE [10] Ext Fault A [11] Ext Fault B [12] Motor Sel. [13] MB BRAKE STATE [14] Accel/Decel SWITCHING [15] Ref_Tuning [INC] [16] Ref_Tuning [DEC] [17] Acc/Dec_By [18] PID Cntl_ENABLE [19] AUTO PID MODE [20] PID GAIN Selection [21] PID Integrator_Reset [22] Trq_Ref_Opt_Bypass [23] Torque_Sign [24] Torque_Output_Zero [25] Timer_RUN Enable [26] Slave_RUN Status [28] Flying_Start [29] Disable Profibus			
P08.16	Ref. Up/Down Time P08.16	s	50.00	0.10 ~ 90.00	0		
P08.17	Flying Start P08.17		0	[0] Disabled [1] Enable	0		
P08.18	"RUN" Delay Time P08.18	s	0.00	0.000 ~ 3.000	0		
P08.19	Tmr_RUN Time P08.19	s	0.00	0.000 ~ 9.000	0		

Parameter Group 9: Multi-Step Reference [Motor 1]

Par. NO	Parameter Name LED Display	Unit	Default	Range	Access Level	Note	Ref. Page
P09.00	JOG Set P09.00	%	20.0	0.0 ~ 300.0	0		
P09.01	Step [1] Set P09.01	%	15.0	0.0 ~ 300.0	0		
P09.02	Step [2] Set P09.02	%	30.0	0.0 ~ 300.0	0		
P09.03	Step [3] Set P09.03	%	50.0	0.0 ~ 300.0	0		
P09.04	Step [4] Set P09.04	%	100.0	0.0 ~ 300.0	0		
P09.05	Step [5] Set P09.05	%	100.0	0.0 ~ 300.0	0		
P09.06	Step [6] Set P09.06	%	100.0	0.0 ~ 300.0	0		
P09.07	Step [7] Set P09.07	%	100.0	0.0 ~ 300.0	0		
P09.08	Step [8] Set P09.08	%	100.0	0.0 ~ 300.0	0		
P09.09	Step [9] Set P09.09	%	100.0	0.0 ~ 300.0	0		

Parameter

Par. NO	Parameter Name LED Display	Unit	Default	Range	Access Level	Note	Ref. Page
P09.10	Step [10] Set P09.10	%	100.0	0.0 ~ 300.0	0		
P09.11	Step [11] Set P09.11	%	100.0	0.0 ~ 300.0	0		
P09.12	Step [12] Set P09.12	%	100.0	0.0 ~ 300.0	0		
P09.13	Step [13] Set P09.13	%	100.0	0.0 ~ 300.0	0		
P09.14	Step [14] Set P09.14	%	100.0	0.0 ~ 300.0	0		
P09.15	Step [15] Set P09.15	%	100.0	0.0 ~ 300.0	0		
P09.16	Unit Selecting P09.16		0	[0] Percent [%] [1] Frequency [Hz]	0		

8

Parameter Group 11: Analog Output Configuration

Par. NO	Parameter Name LED Display	Unit	Default	Range	Access Level	Note	Ref. Page
P11.00	AO.1 output Selection AO1 Sel		1	[0] Output Frequency [1] Motor Speed [2] Output Current [3] Drive Output Voltage [4] Actual Torque [5] Output Power [6] DC-Link Volt [7] Free_Func Output [8] Trim 0 mA [9] Trim 4 mA [10] Trim 20 mA	0		
P11.01	AO.1 Type AO1 Type		0	[0] 0 ~ 20mA [1] 4 ~ 20mA	0		
P11.02	AO.1 Adjustment [0mA] AO1 Tr_0	p-u	0.0530	0 ~ 0.2	0		
P11.03	AO.1 Adjustment [4mA] AO1 Tr_4	p-u	0.2143	0.15 ~ 0.3	0		
P11.04	AO.1 Adjustment [20mA] AO1 Tr_20	p-u	0.856	0.5 ~ 1	0		
P11.05	AO.1 Max_Output AO1 Scale	%	100	0 ~ 300	0		
P11.06	AO.1 Inversion AO1 Inv.		0	[0] Disabled [1] Enabled	0		

Parameter Group 12: Digital Output Setup

Par. NO	Parameter Name LED Display	Unit	Default	Range	Access Level	Note	Ref. Page
P12.00	DO 1 Function P12.00		2	[0] Disabled/Aux_SW_Ctrl [1] Drive Ready [2] Fault Out [A] [3] Fault Out [B] [4] MOTOR BRAKE [5] RUN/STOP STATUS [6] WARNING STATUS [7] DIRECTION [8] JOG INPUT STATE [9] OV/OC/UV LIMITING FUNCTION [10] Free Function	0		
P12.01	DO 2 Function P12.01		5				

8

Parameter Group 13: Motor Brake Control

Par. NO	Parameter Name LED Display	Unit	Default	Range	Access Level	Note	Ref. Page
P13.00	M1 Locked State Up_Spd_Set P13.00	%	4.0	0.0 ~ 100	0		
P13.01	M1 Locked State Down_Spd_Set P13.01	%	0.0	0.0 ~ 100	0		
P13.02	M1_Brk Open Current P13.02	%	25.0	0.0 ~ 200.0	0		
P13.03	M1 START Delay_ Time P13.03	s	0.00	0.00 ~ 5.00	0		
P13.04	M1 Brk_Close Spd_Set P13.04	%	1.0	0.0 ~ 100.0	0		
P13.05	M1_Brk_OPEN_Torque _Build_Time P13.05	s	0.2	0.00 ~ 1.00	0		

Parameter Group 14: Auto Tuning Configuration

Par. NO	Parameter Name LED Display	Unit	Default	Range	Access Level	Note	Ref. Page
P14.00	Motor tuning Condition P14.00		1	[0] Free Rotor [1] Locked Rotor	0		
P14.01	Excitation Slip Frequency P14.01	%	70.0	20 ~ 200	1		
P14.02	Min. Tuning Speed P14.02	rpm	75	-3000 ~ 3000	1		
P14.03	Max. Tuning Speed P14.03	rpm	200	-3000 ~ 3000	1		

Par. NO	Parameter Name LED Display	Unit	Default	Range	Access Level	Note	Ref. Page
P14.04	High-Freq Excitation Frequency P14.04	%	40	10 ~ 100	0		
P14.05	High-Freq Excitation Current P14.05	%	75	10 ~ 100	0		
P14.06	Starting Excitation Current P14.06	%	75	0 ~ 100	0		
P14.07	Low Speed Excitation Flux P14.07	%	100	0 ~ 110	0		
P14.08	Low Speed Excitation Frequency P14.08	Hz	2	0 ~ 10	0		

Parameter Group 15: V/F Control [Motor 1]

Par. NO	Parameter Name LED Display	Unit	Default	Range	Access Level	Note	Ref. Page
P15.00	Torque Compensation P15.00		0	[0] Manual Compensation [1] Auto Compensation	0		
P15.01	Min. output Frequency P15.01	Hz	0.0	0.0 ~ 60.0	0		
P15.02	Max output Frequency P15.02	Hz	60.0	0.0 ~ 120.0	0		
P15.03	Torque Compensation Flux Current P15.03	%	50.0	20.0 ~ 150.0	0		
P15.04	Torque Compensation Time Constant P15.04	ms	500.0	20.0 ~ 900.0	0		
P15.05	Speed Detection Time Constant P15.05	ms	100.0	20 ~ 3000	0		
P15.06	VVVF Pattern P15.06		0	[0] Linear V/F Curve [1] Square V/F Curve [2] Custom V/F Curve [3] Free Function	0		
P15.07	Zero Frequency Voltage P15.07	%	1.5	0 ~ 150	0		
P15.08	Mid. Frequency P15.08	Hz	6.0	1 ~ 90.0	0		
P15.09	Mid. Frequency Voltage P15.09	%	11.0	0 ~ 100	0		

Par. NO	Parameter Name LED Display	Unit	Default	Range	Access Level	Note	Ref. Page
P15.10	Max Voltage Frequency P15.10	%	99.0	0 ~ 300	0		
P15.11	Max. Output Voltage P15.11	%	100.0	0 ~ 150	0		
P15.12	Max. Voltage Limiter P15.12		0	[0] Disabled [1] Enabled	0		
P15.14	Sq_Crv Voltage Compensation P15.14	%	25.0	0 ~ 100	0		
P15.15	DC-Brake Time [START] P15.15	s	0.0	0 ~ 30	0		
P15.16	DC-Brake Blanking Time [START] P15.16	s	0.00	0 ~ 30	0		
P15.17	DC-Brake Current [START] P15.17	%	75.0	0 ~ 150	0		
P15.18	DC-Brake Time [STOP] P15.18	s	0.0	0 ~ 30	0		
P15.19	DC-Brake Blanking Time [STOP] P15.19	s	0.00	0 ~ 30	0		
P15.20	DC-Brake Hold_Current [STOP] P15.20	%	75.0	0 ~ 150	0		
P15.21	DC-Brake Starting_Current [STOP] P15.21	%	90.0	0 ~ 150	0		
P15.24	Stabilization Time Constant P15.24	ms	0.8	0.8 ~ 10	0		
P15.25	Stabilization Gain P15.25	%	10.0	0 ~ 50	0		
P15.26	Stabilization Limit P15.26	%	0.70	0 ~ 2	0		
P15.27	High_Speed Unity_Current_Range P15.27	%	300.0	100 ~ 500	0		
P15.28	Accel_OC_Protection Ctrl_Gain P15.28	%	100	0 ~ 300	0		

Parameter Group 17: Sensor less Vector Control [Motor 1]

Par. NO	Parameter Name LED Display	Unit	Default	Range	Access Level	Note	Ref. Page
P17.00	Speed Detection time _constant P17.00	ms	10.0	5 ~ 20	0		
P17.01	Min. Speed P17.01	rpm	50	0 ~ 3000	0		
P17.02	Max. Speed P17.02	%	100	0 ~ 300	0		
P17.03	Over Speed Limit P17.03	%	125	0 ~ 300	0		
P17.05	Starting Flux P17.05	%	125	50 ~ 140	0		
P17.06	Base Flux P17.06	%	100.0	50 ~ 140	0		
P17.07	Start Flux-END Speed P17.07	%	5.0	0 ~ 50	0		
P17.08	Base Flux-START Speed P17.08	%	25.0	0 ~ 120	0		
P17.09	Field_ Weakening Voltage P17.09	%	99.00	50 ~ 150	0		
P17.10	Field_ Weakening Time Constant P17.10	ms	10.0	1 ~ 1000	0		
P17.11	Current Ctrl Proportional-Gain P17.11	%	100.0	0 ~ 1000	0		
P17.12	Current_Ctrl Integral -Gain P17.12	%	100.0	0 ~ 1000	0		
P17.14	Speed_Ctrl PI Gain P17.14		0	[0] Default Setting [1] Result by Auto-Tuning	0		
P17.15	Load Observer Activation P17.15		0	[0] Disabled [1] Enabled	0		
P17.16	Load Observer Time Constant P17.16	ms	100.0	50 ~ 1000	0		
P17.17	Load Compensation Start Frequency P17.17	Hz	0.0	0 ~ 300	0		
P17.18	Spd_Ctrl Proportional -Gain P17.18	%	100.0	0 ~ 1000	0		
P17.19	Spd_Ctrl Integral-Gain	%	100.0	0 ~ 1000	0		

Par. NO	Parameter Name LED Display	Unit	Default	Range	Access Level	Note	Ref. Page
	P17.19						
P17.20	Spd_Ctrl Ref_Weight_ Factor P17.20	%	99.9	10 ~ 99.9	0		
P17.25	Max_Delta_Lambda_ Coeff P17.25		0.05	0 ~ 0.1			
P17.26	Max_Delta_Theta_ Coeff P17.26		0.01	0 ~ 0.1			
P17.33	Torque Set_Value Source P17.33		0	[0] Speed_Ctrl_Out [1] AI 2 [2] Operator (Keypad,Laptop) [3] SyncCtrl_CommBus [4] Free Function	0		
P17.34	Torque Offset Source P17.34		0	[0] Disable [1] AI 2 [2] Free Function	0		
P17.35	Torque Limit Source P17.35		0	[0] Internal Limit [1] AI 2 [2] SyncCtrl_CommBus [3] Free Function	0		
P17.36	Speed_Limiting_Ctrl Limit_Src P17.36		1	[0] Max. Speed (Parameter) [1] Ext_Speed Set_Value [2] Free Function	0		
P17.37	Speed Limit Control Action P17.37		0	[0] Trq -> Nullify [1] Spd_Regulation [2] Free Function	0		
P17.38	Speed Limiting Ctrl_Offset P17.38	rpm	43	0~3000	0		
P17.39	Speed Limiting Control Gain P17.39	%	100.0	0~500.0	0		
P17.48	Spd_Accel/Decel Trq_Compensation P17.48		0	[0] Disable [1] Enable	0		
P17.49	Inertia_Comp Dfferentiation_Time P17.49	ms	100.0	2 ~ 900.0	0		

Parameter Group 21: Motor 1 Constant

Par. NO	Parameter Name LED Display	Unit	Default	Range	Access Level	Note	Ref. Page
P21.00	Stator Resistance 1 P21.00	mΩ	0	0 ~ 5000	1		
P21.01	Stator Resistance 2 P21.01	mΩ	0	0 ~ 5000	1		
P21.02	Rotator Resistance P21.02	mΩ	0	0 ~ 5000	1		
P21.03	Stator Inductance P21.03	mH	0	0 ~ 10000	1		
P21.04	Rotor Inductance P21.04	mH	0	0 ~ 10000	1		
P21.05	Leakage Inductance P21.05	mH	0	0 ~ 1000	1		
P21.06	Inertia Time Constant (IC) P21.06	s	0.5	0.01 ~ 300	1		
P21.07	Iron Loss Compensation P21.07	%	0.0	0 ~ 300	1		
P21.08	Biscos Damping P21.08	%	0.0	-150 ~ 150	1		

Parameter Group 24: Monitor Setup

Par. NO	Parameter Name LED Display	Unit	Default	Range	Access Level	Note	Ref. Page
P24.02	Key Repetition Time P24.02	s	0.5	0 ~ 2	0		
P24.03	Speed Monitor Method P24.03		0	[0] Calculation [1] Pulse Generator	0		
P24.04	Speed Detection time _Const P24.04	ms	20.0	1 ~ 1000	0		
P24.05	Monitor Filter_Time _Const P24.05	ms	100.0	1 ~ 1000	0		
P24.06	Previous_RUN _Direction P24.06		0	[0] Forward (Upward) [1] Reverse (Downward)	0		
P24.07	Previous_Speed Set_Pt P24.07	Rp m	0	0 ~ 32000	0		
P24.08	Previous_Frequeuncy Set_Pt P24.08	Hz	0	0 ~ 300	0		
P24.09	Previous_Torque Set_Pt P24.09	%	0	-300 ~ 300	0		
P24.10	Previous_PID Set_Pt P24.10	%	0	-300 ~ 300	0		

Par. NO	Parameter Name LED Display	Unit	Default	Range	Access Level	Note	Ref. Page
P24.12	Default Monitor Item P24.12		0	[0] DC_Bus Voltage [1] Line Voltage [2] Line Frequency [3] Line Current [4] Active Power [5] Reactive Power [6] Power Factor	0		
P24.13	Left/Right Button Spd_Set [Hz] P24.13	Hz	0.5	0.01 ~ 100	0		
P24.14	Left/Right Button Spd_Set [rpm] P24.14	rpm	10	1 ~ 2000	0		
P24.17	AC_Run_Time_10hr P24.17	10hr	0	0~32000	0		
P24.18	AC_Run_Time_hr P24.18	hr	0	0~10	0		
P24.19	AC_Run_Time_min P24.19	min	0	0~60	0		
P24.20	AC_Run_Time_sec P24.20	Sec	0	0~60	0		

8.2. Parameter Description

Parameter Access Level description

Level 0: readable / writable

Level 1: readable /not writable (have to be authorized to write)

Level 2-5: not readable /not writable (have to be authorized to read and write)

8.2.0 Parameter Group 0 : Program Control

[0] Standard I :

※ V/F Frequency Control

This controls the motor output voltage and output frequency.

Refer to Parameter 01.06 for setting the control mode.

Related Parameters: Parameter Group 1, 15.

※ Sensor less Vector Speed Control

In this control method, it controls a motor with no rotation speed feedback of the motor. Magnetic flux and torque current are controlled respectively. This control can be used when there should be enough torque, or there is a sharp fluctuation in load at start-up or low speed.

Related Parameter s: Parameter Group 1, 14, 17, 18, 21. And Auto-Tuning is necessary. The related parameters to Auto-Tuning are Parameter Group 1, 14, 21. The parameters in Group 21 is automatically generated by Auto-Tuning.

P00.12 Initialization Permission Key

P00.14 Nominal Frquency Class

[0] 50Hz Class

[1] 60Hz Class

P00.15 Thermal Monitor Class

[0] Thermal_State_Relay

[1] NTC_Thermistor

8.2.1 Parameter Group 1 : Control Setup [Motor 1]

P01.00 Rated Power

Set up the rated power of a motor. Refer to the rating plate on the motor.

P01.01 Rated Voltage

Set up the rated voltage of a motor. Refer to the rating plate on the motor.

P01.02 Rated Current

Set up the rated current of a motor. Refer to the rating plate on the motor.

P01.03 Rated Frequency

Set up the rated frequency of a motor. Refer to the rating plate on the motor.

P01.04 Number of Poles

Set up number of poles of a motor. Refer to the rating plate on the motor.

P01.05 Rated Speed

Set up the rated speed of a motor. Refer to the rating plate on the motor.

P01.06 Control Method

[0] V/F Freq (V/F Frequency Control)

This can be used when Standard I or Standard II is used for Program Key.

[2] S/L_Vector (Sensor less Vector Speed Control)

This can be used when Standard I is used for Program Key.

P01.07 PWM Frequency

Set up the switching frequency for the internal switching part of the inverter.

If the switching frequency low, the noise signal from inverter gets reduced and the leakage current gets smaller, but the noise sounds become loud. If it does not bother with high temperature and noise sound, set the switching frequency low.

If this parameter is changed, execute [0] Drive Calibration in Main Menu page [3] Auto Tuning of 6.2.4.

P01.09 Supply Voltage

Set up the magnitude of the 3-phase voltage connected to the inverter.

8.2.3 Parameter Group 3 : Reference Setup [Motor 1]

These parameters are applied when using Motor 1(Parameter Group 1).

P03.00 RUN/STOP Method

This selects the input method of Run and Stop signal.

[0] Terminal

Use I/O terminals (DI1, DI2 etc.) for the method of inputting the command signals for operation/stop.

[1] Operator (Keypad, PC)

Use Keypad or PC for the method of inputting the command signals for operation/stop.

[2] Synchronous_Ctrl

[3] Fieldbus

[4] Free Function Logic

P03.01 Ramp Function Input Mode

Set the method of inputting the speed or frequency reference. The reference is displayed by frequency [Hz] for V/F Frequency Control and by speed[rpm] for Speed Control or Vector Control.

[0] Terminal

Command the speed or frequency by I/O terminals. The reference sources are selected from Voltage, current or multi-steps.

[1] Operator

Command the speed or frequency reference by Keypad or PC.

[2] Synchronous_Ctrl

[3] Free Fuction

P03.02 STOP Command Detection Time

The NC inverter executes the stop mode after elapse of the set time in P03.02. Refer to Figure 8.2-1.

P03.03 STOP Mode

Set the method for reducing the speed of the motor rotation when the stop mode is executed.

Refer to Figure 8.2-1.

[0] Ramp STOP

The motor rotational speed is decreased to 0, depending on the deceleration time set from P03.26 ~ P03.41.

[1] Free-Run STOP

The inverter cuts off the output immediately as soon as the stop mode is executed.

[2] Mixed STOP

This is the mode that is combined Ramp Stop and Free-Run Stop. On Ramp Stop, if the speed of motor rotation goes down under the reference set by P03.06, this mode is changed to Free-Run Stop.

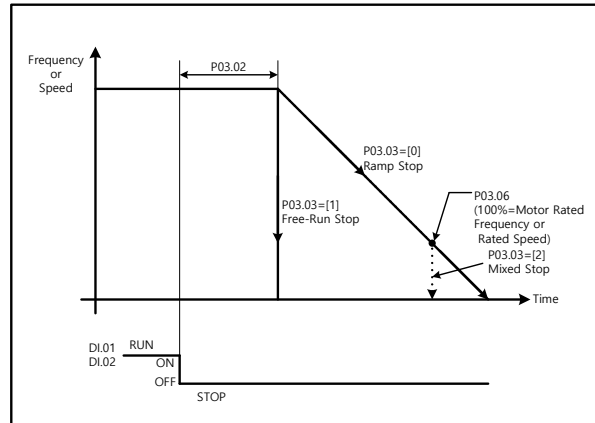

Figure 8.2-1 Inverter Stop Function

P03.04 STOP Hold Time

The inverter maintains the operation mode for the set time in parameter even though the speed of motor is 0. And when set time is passed out, inverter is changed to Stop mode. This function is only applied when P03.03 Stop mode is set up [0] Ramp STOP. Refer to the Figure 8.2-2.

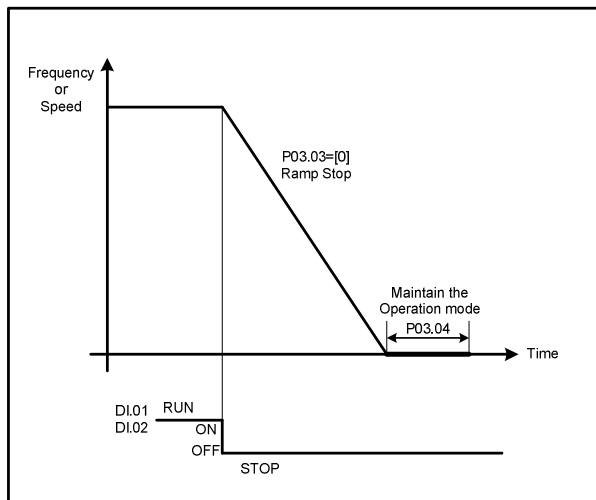

Figure 8.2-2 Stop Hold Time

P03.05 Output Off Hold Time

This sets the time from the moment that the inverter is stopped until the inverter generates the output again in operation mode. After stopped motor, inverter doesn't generate output even though the operation signal comes in the inverter within the time set by parameter. Refer to the Figure 8.2-3. This function is only applicable Free-Run Stop.

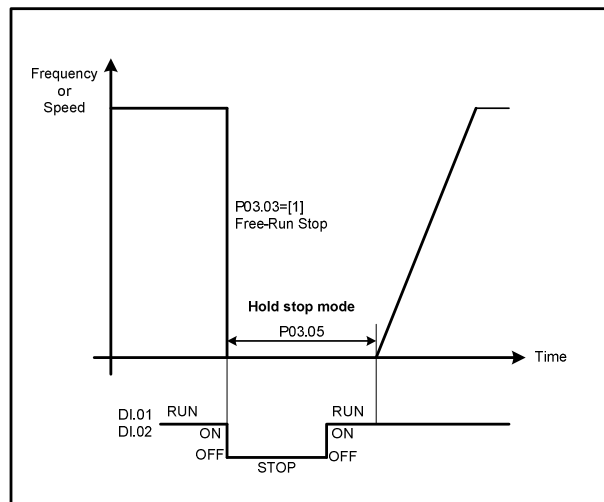

Figure 8.2-3 Output Off Hold Time

P03.06 Mixed-mode STOP Reference

This sets the speed reference that converts Ramp Stop to Free-Run Stop when the stop mode is the [2]Mixed Stop. Refer to the Figure 8.2-1.

P03.07 Acc/Dec Ramp Function**[0] Disabled**

There is no Acceleration./ Deceleration time.

[1] Enabled

The speed of motor is accelerated or decelerated by the set value of Acceleration / Deceleration time and pattern.

P03.08 Acceleration Time Range**[0] X 1sec**

Use this option when the acceleration time is between 0 and 300 [s].

[1] X 10sec

Use this option when the acceleration time is over 300 and goes up to 3000 [s].

P03.09 Acceleration Switch Ref 1-2

This is the frequency or speed reference that determines “acceleration range 1”. Refer to the figure 8.2-4.

P03.10 Acceleration Switch Ref 2-3

This is the frequency or speed reference that determines “acceleration range 2” Refer to the figure 8.2-4

P03.11 Acceleration Switch Ref 3-4**P03.12 Acceleration Switch Ref 4-5****P03.13 Acceleration Switch Ref 5-6****P03.14 Acceleration Switch Ref 6-7****P03.15 Acceleration Switch Ref 7-8****P03.16 Acceleration Time I.1**

This is the acceleration time from 0 to P03.09. (Acceleration range 1)
Refer to the figure 8.2-4.

P03.17 Acceleration Time I.2 (Acceleration range 2 in acceleration section 1)

This is the acceleration time from P03.09 to P03.10. (Acceleration range 2)
Refer to the figure 8.2-4.

P03.18 Acceleration Time I.3 (Acceleration range 3 in acceleration section 1)

This is the acceleration time form P03.10 to the maximum reference.
(Acceleration range)

Refer to the figure 8.2-4.

- P03.19 Acceleration Time I .4 (Acceleration range 2 in acceleration section 1)**
- P03.20 Acceleration Time I .5 (Acceleration range 2 in acceleration section 1)**
- P03.21 Acceleration Time I .6 (Acceleration range 2 in acceleration section 1)**
- P03.22 Acceleration Time I .7 (Acceleration range 2 in acceleration section 1)**
- P03.23 Acceleration Time I .8 (Acceleration range 2 in acceleration section 1)**

For a detailed setting of the acceleration time and acceleration range, refer to the description in Figure 8.2-4 in the following chapter.

Condition	#Speed or Frequency reference:0 ~ 10V #motor rated frequency or speed : 60Hz, 1770rpm	
Operation Up to the Motor rated Frequency Or Motor rated speed (operation up to 100%)	When there is Only one range 	P01.03 = 60Hz (motor rated freq.) P01.05=1770rpm (motor rated spd.) P03.09 = 100% (default) P03.10 = 200% (default) P03.16 = 5s P03.17, P03.18 = not used P06.06 = 0.00V (AI 1 Min. Volt) P06.08 = 0 % (AI 1 Min. Scale) P06.09 = 10.00V (AI 1 Max. Volt) P06.11 = 100 % (AI 1 Max. Scale) P15.02 = 60 Hz (Max. Freq.) P17.02 = 1770 rpm (Max. Speed) P19.04 = 1770 rpm (Max. Speed)
	When the operation range is divided. 	P01.03 = 60Hz (motor rated freq.) P01.05= 1770rpm (motor rated spd) P03.09 = 30% P03.10 = 60% P03.16 = 1.2 s P03.17 = 1.5s P03.18 = 1.3s P06.06 = 0.00V (AI 1 Min. Volt) P06.08 = 0 % (AI 1 Min. Scale) P06.09 = 10.00V (AI 1 Max. Volt) P06.11 = 100 % (AI 1 Max. Scale) P15.02 = 60 Hz (Max. Freq.) P17.02 = 1770 rpm (Max. Speed) P19.04 = 1770 rpm (Max. Speed)
Operation over the Motor rated Frequency Or Motor rated speed (Over 100%, Operate 150%)	When there is Only one range 	P01.03 = 60Hz (motor rated freq.) P01.05= 1770rpm (motor rated spd) P03.09 = 150% P03.10 = 200% (default) P03.16 = 7 s P03.17, P03.18 = not used P06.06 = 0.00V (AI 1 Min. Volt) P06.08 = 0% (AI 1 Min. Scale) P06.09 = 10.00V (AI 1 Max. Volt) P06.11 = 150% (AI 1 Max. Scale) P15.02 = 90 Hz (Max. Freq.) P17.02 = 2655 rpm (Max. Speed) P19.04 = 2655 rpm (Max. Speed)
	When the operation range is divided. 	P01.03 = 60Hz (motor rated freq.) P01.05= 1770rpm (motor rated spd) P03.09 = 60% P03.10 = 100% P03.16 = 1.5 s P03.17 = 3.0 s P03.18 = 2.5 s P06.06 = 0.00V (AI 1 Min. Volt) P06.08 = 0% (AI 1 Min. Scale) P06.09 = 10.0 V (AI 1 Max.Volt) P06.11 = 150% (AI 1 Max. Scale) P15.02 = 90 Hz (Max. Freq.) P17.02 = 2655 rpm (Max. Speed) P19.04 = 2655 rpm (Max. Speed)

Figure 8.2-4 Setting for Acceleration time and range

P03.24 Acceleration Time II

When DI Function is set to [14] Acc./Dec Switching, the value of Deceleration Time II is applied to the Deceleration time from the rated speed (or frequency) to zero speed (or frequency) as DI receives the switching signal.

P03.25 Deceleration Time Range**[0] X 1sec**

Use this option when the deceleration time is up to 300 [s].

[1] X 10sec

Use this option when the deceleration time is up to 3000 [s].

P03.26 Deceleration Switch Ref 1-2

This is the frequency or speed reference that changes from deceleration range 2 to deceleration range 1.

Refer to the figure 8.2-5.

P03.27 Deceleration Switch Ref 2-3

This is the frequency or speed reference that changes from deceleration range 3 to deceleration range 2.

Refer to the figure 8.2-5.

P03.28 Deceleration Switch Ref 3-4**P03.29 Deceleration Switch Ref 4-5****P03.30 Deceleration Switch Ref 5-6****P03.31 Deceleration Switch Ref 6-7****P03.32 Deceleration Switch Ref 7-8****P03.33 Deceleration Time I.1 (Deceleration range 1 in deceleration section 1)**

This is the deceleration time from P03.26 to 0. (Deceleration range 1)

Refer to the figure 8.2-5.

P03.34 Deceleration Time I.2 (Deceleration range 2 in deceleration section 1)

This is the deceleration time from P03.27 to P03.26. (Deceleration range 2)

Refer to the figure 8.2-5.

P03.35 Deceleration Time I.3 (Deceleration range 3 in deceleration section 1)

This is the deceleration time from Max. reference to P03.27. (Deceleration range 3)

Refer to the figure 8.2-5.

P03.36 Deceleration Time I.4 (Deceleration range 3 in deceleration section 1)**P03.37 Deceleration Time I.5 (Deceleration range 3 in deceleration section 1)****P03.38 Deceleration Time I.6 (Deceleration range 3 in deceleration section 1)****P03.39 Deceleration Time I.7 (Deceleration range 3 in deceleration section 1)****P03.40 Deceleration Time I.8 (Deceleration range 3 in deceleration section 1)**

For a detailed setting of the deceleration time and deceleration range, refer to the description in Figure 8.2-5 in the following chapter.

Condition	#Speed or Frequency reference:0 ~ 10V #motor rated frequency or speed : 60Hz, 1770rpm		
Operation Up to the Motor rated Frequency Or Motor rated speed (operation up to 100%)	When there is Only one range		P01.03 = 60Hz (motor rated freq.) P01.05 = 1770rpm (motor rated spd) P03.26 = 100% (default) P03.27 = 200% (default) P03.33 = 5s P03.34, P03.35 = not used P06.06 = 0.00V (AI 1 Min. Volt) P06.08 = 0 % (AI 1 Min.Scale) P06.09 = 10.00V (AI 1 Max. Volt) P06.11 = 100 % (AI 1 Max.Scale) P15.02 = 60 Hz (Max. Freq.) P17.02 = 1770 rpm (Max. Speed) P19.04 = 1770 rpm (Max. Speed)
	When the operation range is divided.		P01.03 = 60Hz (motor rated freq.) P01.05 = 1770rpm (motor rated spd) P03.26 = 30% P03.27 = 60% P03.33 = 1.2 s P03.34 = 1.5s P03.35 = 1.3s P06.06 = 0.00V (AI 1 Min. Volt) P06.08 = 0 % (AI 1 Min.Scale) P06.09 = 10.00V (AI 1 Max. Volt) P06.11 = 100 % (AI 1 Max.Scale) P15.02 = 60 Hz (Max. Freq.) P17.02 = 1770 rpm (Max. Speed) P19.04 = 1770 rpm (Max. Speed)
Operation over the Motor rated Frequency Or Motor rated speed (Over 100%, Operate 150%)	When there is Only one range		P01.03 = 60Hz (motor rated freq.) P01.05 = 1770rpm (motor rated spd) P03.26 = 150% P03.27 = 200% (default) P03.33 = 7 s P03.17, P3.18 = not used P06.06 = 0.00V (AI 1 Min. Volt) P06.08 = 0% (AI 1 Min.Scale) P06.09 = 10.00V (AI 1 Max. Volt) P06.11 = 150% (AI 1 Max.Scale) P15.02 = 90 Hz (Max. Freq.) P17.02 = 2655 rpm (Max. Speed) P19.04 = 2655 rpm (Max. Speed)
	When the operation range is divided.		P01.03 = 60Hz (motor rated freq.) P01.05 = 1770rpm (motor rated spd) P03.26 = 60% P03.27 = 100% P03.33 = 1.5 s P03.34 = 3.0 s P03.35 = 2.5 s P06.06 = 0.00V (AI 1 Min. Volt) P06.08 = 0% (AI 1 Min.Scale) P06.09 = 10.00V (AI 1 Max. Volt) P06.11 = 150% (AI 1 Max.Scale) P15.02 = 90 Hz (Max. Freq.) P17.02 = 2655 rpm (Max. Speed) P19.04 = 2655 rpm (Max. Speed)

Figure 8.2-5 Setting for Deceleration time and range

P03.41 Deceleration Time II

When DI Function is set to [14] Acc./Dec Switching, the value of Deceleration Time II is applied to the Deceleration time from the rated speed (or frequency) to zero speed (or frequency) as DI receives the switching signal.

P03.42 Counter Deceleration Function

Set up the reverse deceleration function.

P03.43 Counter Deceleration

Set up the reverse deceleration time.

P03.49 Emergency Stop Mode

When digital input function of parameter group 8 is set to [1] Drive Enable, Emergency Stop Mode sets the method to decelerate the motor when the Enable signal is removed at the digital input terminal during the operation. Refer to P03.03 STOP Mode for instruction.

[0] Ramp STOP

[1] Free-Run STOP

[2] Mixed STOP

P03.50 Emergency Stop Deceleration Time

When digital input function of parameter group 8 is set to [1] Drive Enable, Emergency Stop Mode sets the deceleration time of motor when the Enable signal is removed at the digital input terminal during the operation. This is only applied when the stop mode is the Ramp stop mode, P03.49.

P03.51 Continuous OP Mode

Select the operation mode.

[0] Disabled

If the stop signal is entered and the operation signal is entered again, the inverter power is switched on again after output of inverter reached 0.

[1] Enabled

When the operating signal is input, the inverter starts even if the output of the inverter is not 0.

P03.52 Reverse Direction Operation

[0] Disabled

[1] Enabled

8.2.5 Parameter Group 5 : Protection**P05.00 Current Limit [Motor 1]**

P05.07 Maximum Continuous Current

Set the maximum current for the possible continuous operation.

(100%= the value of rated motor current, P01.02) Refer to the figure 8.2-7.

P05.08 Over-Load Current**P05.09 Over-Load Time-over**

The protection function starts working when output current with the current value set in P05.08 is exceeded to the time set in P05.09.

Also, the protection function starts working when the output current is over P05.07 or under P05.08 in above the time set in P05.09. Refer to the figure 8.2-6.

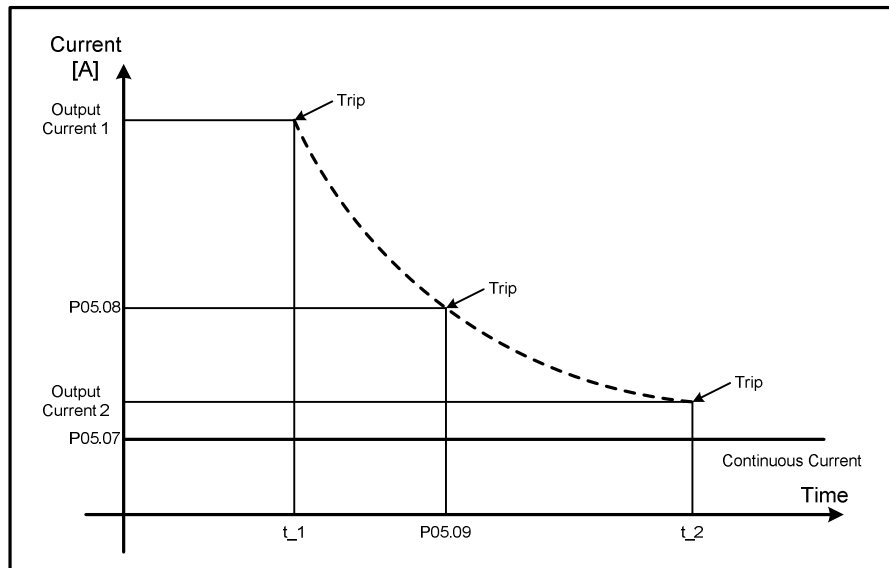

Figure 8.2-6 Set up Over Load

P05.10 Over Load Fault [Action]

Select Stop Function when Over Load Fault occurs.

[0] **Normal Stop** : Stopping Inverter in the mode set in P03.03 or P04.03.

[1] **E-STOP**

[2] **Ctrl_OFF**

[3] **IGNORE** : Keeping operation of Inverter – Warning.

P05.11 Over Current Trip

The Fault occurs when the output exceeds the Over Current trip level.

(100%=the value of rated motor current, P01.02)

P05.12 Zero-sequence Current trip

If the current addition of the three phases exceeds the set value, the protection starts working.

P05.13 Over Voltage Limiting Function

Select whether it uses the Over Voltage Limiting Function or not.

[0] Disabled : Not use the over voltage limiting function.

[1] Enabled : Use the over voltage limiting function.

P05.14 Over Voltage Limit

Set the level of the DC link voltage at which the Over Voltage Limit function operates.

This operates as only setting in P05.13="[1] Enabled". When the DC link voltage of the inverter reaches the set value of this parameter, the output frequency or speed is automatically adjusted to prevent the DC link voltage from rising above the set value.

P05.15 Over Voltage Trip

Protection will operate if the DC link voltage of the inverter rises above this parameter set value.

P05.16 Under Voltage Compensation

Determines whether it compensate or not for the Under Voltage Compensation.

[0] Disabled : Not use the under voltage compensation function.

[1] Enabled : Use the under voltage compensation function.

P05.17 Under Voltage Compensation Limit

Sets the level of the DC link voltage at which the Low Voltage Compensation function operates.

This operates as only setting in P05.16="[1] Enabled". If the DC link voltage of the inverter is below the set value for this parameter, the output frequency or speed is automatically adjusted to prevent the DC link voltage from becoming below the set value.

P05.18 Under Voltage trip

Protection will operate when the DC link voltage of the inverter goes below the parameter set value.

P05.19 Open Phase Protection

Set the Open Phase Protection. The inverter generates a fault when the open phase happens.

[0] Disabled : Not use the open phase protection function

[1] Enabled : Use the open phase protection function

P05.20 Supply Frequency

Set the Supply Frequency.

P05.21 Built-in DB(Dynamic Brake)

Select whether using brake chopper or not inside of Inverter. Unless the brake chopper

is installed, set up "[0] Disabled"

- [0] Disabled
- [1] Enabled
- [2] Enabled [RUN/STOP]

P05.23 DB Start

P05.24 DB Full Voltage

P05.25 Over Temperature Fault[Action]

Select the Over Heat Function when the fault conditions occur.

- [0] STOP: Stopping Inverter in the mode set in P03.03 or P04.03.
- [1] E-STOP
- [2] Ctrl_OFF
- [3] IGNORE: Keeping operation of Inverter – Warning.
- [4] SPEED_DOWN

P05.30 Auto-Restart Count

Set the number of times to restart after automatic reset if a fault occurs between P05.31 and P05.35. After stopping and waiting for the time set in P05.31, if the inverter operate and the fault occurs again within 30 seconds, the counter will increase by 1. If the number of accumulated counts exceed the parameter set value, it is no longer automatic reset and must be reset manually. If no fault occurs after automatic reset, the number of accumulated counts is reduced by one every 30 seconds. Refer to the figure 8.2-7.

P05.31 Retry Delay Time

Set the waiting time for reset after the fault from P05.32 to P05.37 occurs.

Refer to the figure 8.2-7.

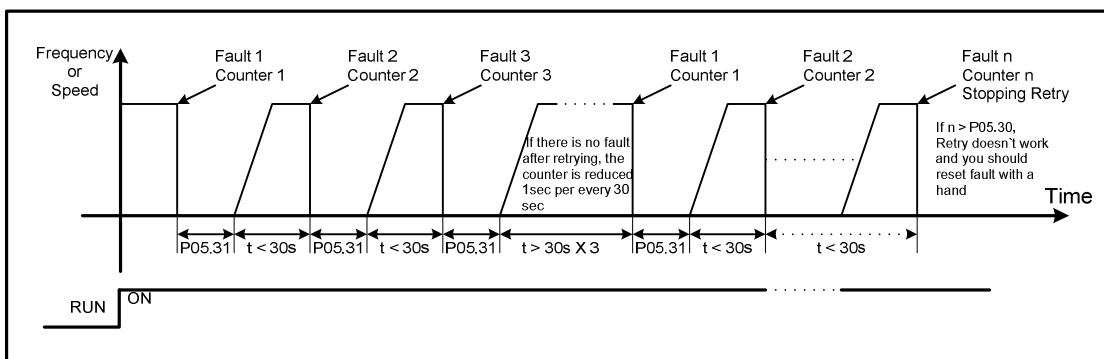

Figure 8.2-7 Auto Retry Function

P05.32 Auto Reset (Over Current)

Set whether the Auto Reset is used when the over current fault occurs.

[0] Disabled

[1] Enabled

P05.33 Auto Reset (Over Voltage)

In case that over current protection is working, determines whether the inverter uses the Auto-Reset function

[0] Disabled

[1] Enabled

P05.34 Auto Reset (Under Voltage)

In case that lower voltage fault is working, determines whether the inverter uses the Auto-Reset function

[0] Disabled

[1] Enabled

P05.37 Out of Control Auto Reset

In case that out-of-control fault is working, determines whether the inverter uses the Auto-Reset function

P05.38 Out of Control Time

If the inverter goes out of control, then it issues a fault. For regulations on current amount that are out of control, see P05.39.

P05.39 Out of Control Current [Motor1]

It is revised the amount of current in the state of out of control of Inverter.

100% of this parameter is the set value of Current Limit in P05.00 or P05.01. As an example, when the set value of the rated motor current is 50[A] and the set value of Current Limit is 180%, the current value is $(50[A] \times 180\%) \times 95\% = 85.5[A]$ with setting in P05.39 as 95% in the state of the out of control of Inverter.

※In case that P01.06 Control Mode is [0] V/F Freq or [1]V/F Speed.

If the output frequency is fewer than 5% of the rated motor frequency and the output current is generated over the value set in P05.39 and these conditions are continued over the set time, Control Disable Fault occurs.

※In case that P01.06 Control Mode is S/L or Vector Control.

If the standard value of speed and real value of speed have a difference, the output current is generated over the value set in P05.39 and this condition is continued over the time set in P05.38, Control Disable Fault occurs.

P05.40 Over Temperature Trip

If output frequency of inverter exceeds by 45Hz while operating, overheat fault occurs

when temperature on the heat sink is evaluated over set value in P05.40.

If output frequency of inverter is less than 45Hz, the overheated detection temperature of inverter can be changed as output current and output frequency in P05.40.

8.2.6 Parameter Group 6 : Analog Input

P06.00 Analog Reference Source

This parameter is applied when setting Analog Function= "[1] AI of P06.01(AI.1), P06.15(AI.2), P06.29(AI.3), P06.43(AI.4), and P06.57(AI.5).

[0] Disabled

Not use or prohibit the Analog Input Terminals.

[1] AI 1

When Analog Input Function is set to [1] AI 1 in P6.1, the order value which is input to analog input terminal is used as operation order signal.

[2] AI 2

When Analog Input Function is set to [1] AI 2 in P6.1, the order value which is input to analog input terminal is used as operation order signal.

P06.01 Analog Input 1 Function (Analog Input Function)

Set the Analog input terminal AI.1 function.

[0] Disabled

[1] AI 1

P06.02 Analog Input 1 Type

Select the signal that is connected to AI.1 in analog input terminals.

[0] 0V ~ 10(5)V

[1] -10V ~ +10V : The direction of rotation is determined by polarity.

[2] 4 ~ 20mA

[3] 0 ~ 20mA

P06.04 Analog Input 1 Filter Time Constant

Set the filtering time constant of the Analog Input reference that is entered on the analog input terminal. (AI.1)

P06.05 Analog Input 1 Offset adjustment

Set the Offset value of the Analog Input reference that is entered on the analog input terminal. (AI.1)

- P06.06 Analog Input 1 min Voltage**
- P06.07 Analog Input 1 min Current**
- P06.08 Analog Input 1 Minimum**
- P06.09 Analog Input 1 max.Voltage**
- P06.10 Analog Input 1 max.Current**
- P06.11 Analog Input 1 Maximum**

Refer to the figure 8.2-8.

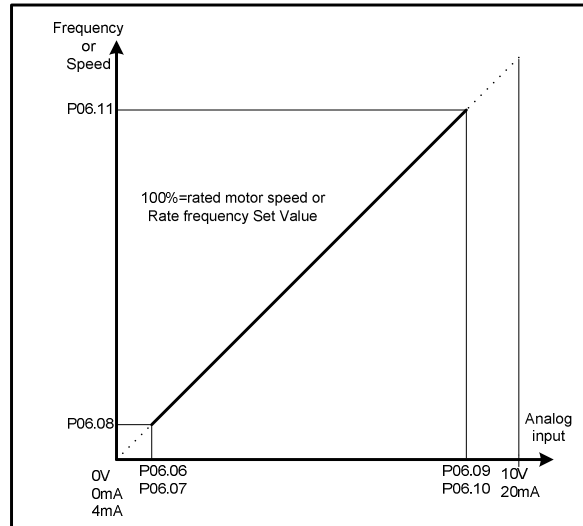

Figure 8.2-8 Setting the Analog Input Scale

P06.12 Analog Input 1 Inversion

Set whether to use reversal of the analog input reference entered on the analog input terminal. (AI.1)

[0] Disabled

[1] Enabled

P06.13 Analog Input 1 Discreteness

In the same step range, the speed or frequency output can be constant, regardless of the level of the analog input.

Use it to achieve a good effect when the system can be affected by small analog input changes.

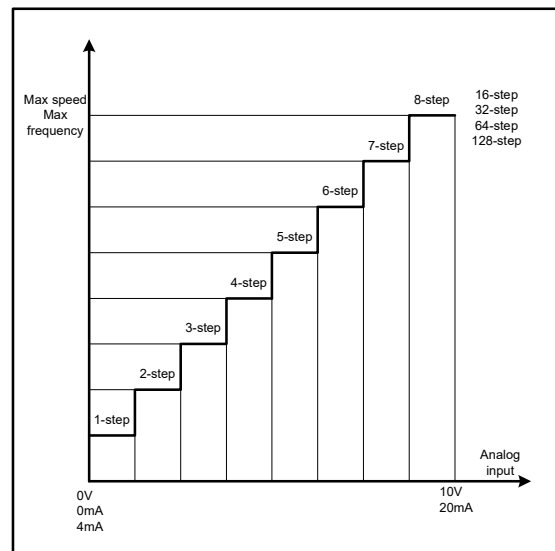

Figure 8.2-9 Setting the Analog Input Step

P06.14 Analog Input 1 Dead-Zone

This is the zone that the inverter is not operating. If the analog input reference is smaller than the value of P06.06 or P06.07, the inverter does not generate the output even though the "RUN" signal comes in. Refer to the figure 8.2-10.

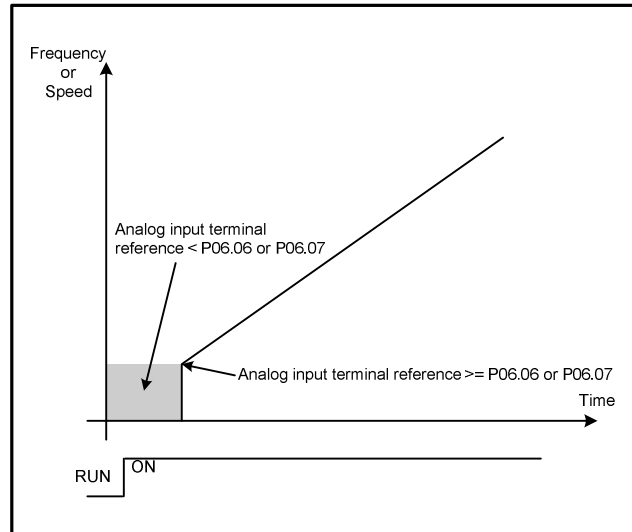

Figure 8.2-10 The Dead-Zone of Analog Input

8.2.8 Parameter Group 8 : Digital Input (Digital Input Terminal Function)

Function selection for digital input terminals. Refer to Chapter 4 of the manual for location and description of each terminal.

P08.00 Run/Stop Control

Set function of DI 1 and DI 2. (Terminal number 5, 6)

[0] 1.FWD/2.REV

DI 1 -> FWD, DI 2 -> REV

DI 1 : Run signal & Forward

DI 2 : Run signal & Reverse

Either DI 1 or DI 2, the first entered digital signal is preferred.

[1] 1.RUN/2.DIR

DI 1 -> RUN, DI 2 -> DIR

DI 1 : Run signal

DI 2 : Open – Forward / Close – Reverse

P08.01 DI 3 Function (Terminal number 7)**P08.02 DI 4 Function (Terminal number 8)****P08.03 DI 5 Function (Terminal number 9)**

It sets the Functions for Digital Input Terminals.

[0] None

Using the contact point input terminal is prohibited or is not.

[1] Drive En. (Drive Enable)

The signal is used for inverter operation ready.

* The activating of "RUN" signal has to be delayed 15ms after the activating of "Drive Enable" signal.

[2] MultiStep.0

Use the signal for Multi-Step 0.

[3] MultiStep.1

Use the signal for Multi-Step 1.

[4] MultiStep.2

Use the signal for Multi-Step 2.

[5] MultiStep.3

Use the signal for Multi-Step 3.

[6] Fault Reset

Use the signal for reset the faults.

[7] JOG

Use the signal for JOG run.

[8] AI_REF_Active

In case of taking the Analog input signal from DI terminal, the Analog input signal is disregarded when the signal [7] is taken in the set terminal.

[9] AI_LOCAL / REMOTE (AI_Local / Remote)

Use the signal for Local or Remote selection.

[10] Ext Fault A (External Fault A)

Use the signal for external fault input. (A-contact)

[11] Ext Fault B (External Fault B)

Use the signal for external fault input. (B-contact)

[12] Motor Sel. (Motor Select)

Use the signal for motor selection. Depending on the contact input, the inverter is operated using the relevant parameters of motor 1 and 2.

Open = Select motor 1 / Close = Select motor 2

[13] MB BRAKE STATE

Use the signal for activating status of motor brake.

[14] Accel/Decel (Acceleration/Deceleration Switching)

Use the signal for selecting the Acc./Dec. time 2.

[15] Ref_Tuning [INC] (Reference Increment)

[16] Ref_Tuning [DEC] (Reference Decrement)

If a contact point signal is entered, the reference value is increased or decreased. And then, if there is no signal, the speed is continued. If a contact point signal is reentered, the reference value is increased or decreased again. The speed re-operated after stopped is same speed as before stopped. If the power is turned off and then turned on again, the speed is back the initial reference speed.

[17] Acc/Dec_Byp (Accel/Decel Bypass)

If a contact point signal is entered, controller ignores the Acc./Dec. time and handle immediately.

[18] PID Cntl_ENABLE (PID Control Enable)

This decides whether PID is used by contact point. If PID is not used, the inverter receives references by the set condition of P03.00 and P03.01. This function is only applied when P07.00(PID Control Mode) is selected.

[19] AUTO PID MODE

This is the same as P07.23, and this is set by contact point.

[20] PID_GAIN (PID Gain Selection)

It is used when the gain on the PID changes. If no input signal is present, P07.07 ~ P07.10 are used, and is so, P07.12 ~ P07.15 are used.

[21] RST_PID_INT (PID Integrator Reset)

This makes the output of PID integrator to 0.

[22] Trq_Ref Opt_Bypass

[23] Torque_Sign

[24] Torque_Output_Zero

[25] Timer_RUN Enable

[26] Slave_RUN Status

[28] Flying_Start

[29] Disable Profibus

P08.16 Ref. Up/Down Time

This is the Acc./Dec. time for the contact input function [15] Ref_UP" / "[16] Ref_DOWN of parameter group 8.

P08.17 Start Delayed JOG Detection

Set up the time that is delayed to recognize the JOG signal to run the Inverter. After recognizing JOG signal, the operation is delayed as set time.

P08.18 "RUN" Delay Time

Set up the time that is delayed to recognize the RUN signal to run the Inverter. After recognizing RUN signal, the operation is delayed as set time.

P08.19 Tmr_RUN Time

8.2.9 Parameter Group 9 : Multi-Step Reference [Motor 1]

This parameter is applied when Motor 1 is selected (parameter group 1).

P09.00 JOG Reference

Set the Jogging reference in percentage of the motor rated speed.

P09.01 ~ P09.15 : Multi Step.1 Ref ~ Multi Step.15 Ref

These parameters are used for the speed reference when the multi-step operation is used. If P09.16 is [0]Hz, set the demanded frequency as each step.

If P09.16 is [1]%, set the percentage(%) for the rated motor speed(frequency).

If there is no any multi-stage speed signal, the motor is operated with the reference of the analog or the minimum speed

STEP INPUT	1	2	3	4	5	6	7	8	9	10	11	12	13	14	15
Mult Step 0	ON	X	ON	X	ON	X	ON	X	ON	X	ON	X	ON	X	ON
Mult Step 1	X	ON	ON	X	X	ON	ON	X	X	ON	ON	X	X	ON	ON
Mult Step 2	X	X	X	ON	ON	ON	ON	X	X	X	X	ON	ON	ON	ON
Mult Step 3	X	X	X	X	X	X	X	ON	ON	ON	ON	ON	ON	ON	ON

P09.16 Unit Selection

[0] Percent [%]

[1] Frequency [Hz]

8.2.11 Parameter Group 11 : Analog Output Configuration

These parameters are related to Analog Output.

P11.00 Analog Output 1 selection

Select the range of output signal from Analog output 1 terminal. (Terminal number 10 and 11)

[0] Frequency (Output Frequency)

[1] Motor Speed

[2] Output Current (Motor Current)

[3] Drive Output Voltage

[4] Torque (Actual Torque)

[5] Power Out (Output Power)

[6] DC_L Volt (DC_Link Voltage)

[7] Free_Func Output

[8] Trim 0 mA

[9] Trim 4 mA

[10] Trim 20 mA

P11.01 Analog Output 1 Type

Select the range of output signal from Analog output 1 terminal.

[0] 0 ~ 20mA

[1] 4 ~ 20mA

P11.02 Analog Output 1 Adjustment 0 mA

First set P11.00 to [8] Trim 0mA, and then, adjust the value of this parameter until the output current becomes 0mA. This is for fine tuning.

P11.03 Analog Output 1 Adjustment 4 mA

First set P11.00 to [9] Trim 4mA, and then, adjust the value of this parameter until the output current becomes 4mA. This is for fine tuning.

P11.04 Analog Output 1 Adjustment 20 mA

First set P11.00 to [10] Trim 20mA, and then, adjust the value of this parameter until the output current becomes 20mA. This is for fine tuning.

P11.05 Analog Output 1 Output at 20mA

Set the value of Analog output selection of P11.00 when the analog output is 20mA.

[0] Output Frequency = 100% = P01.03

[1] Motor Speed = 100% = P01.05

[2] Motor Current = 100% = P01.02

[3] Motor Voltage = 100% = P01.01

[4] Torque

[5] Power Output = 100% = P01.00

[6] DC Link Voltage

P11.06 Analog Output 1 Inversion

[0] Disabled

[1] Enabled

8.2.12 Parameter Group 12 : Digital Output

P12.00 DO 1 Function

P12.01 DO 2 Function

Select the Function of Digital Output.

[0] Disabled / Aux_SW_Ctrl

Not use or prohibit the Digital Output Function.

[1] Drive Ready

It is activated when the inverter operation is ready.

[2] Fault Out [A]

It is activated when a fault occurs. (A – Contact)

[3] Fault Out [B]

It is activated when a fault occurs. (B – Contact)

[4] DM_Brake (Motor Brake)

If the conditions of Brake control of Motor 1 meet the requirements, it is activated or inactivated.

[5] RUN / STOP STATUS

If the conditions of Brake control of Motor 2 meet the requirements, it is activated or inactivated.

[6] WARNING (Warning Status)

It is activated when a warning occurs.

[7] Direction

It is activated when reverse signal enters.

[8] JOG State (Jog Input State)

It is activated when Jogging signal enters.

[9] OV/OC/UV Limit (OV/OC/UV Limiting Function)

It is activated when Over Voltage limiting function or Over Current limiting Function is running.

[10] Free Function**8.2.13 Parameter Group 13 : Motor Brake Control**

Set up the condition for controlling a brake, when the brake is installed to a motor.

Use the contact output terminal set in "[4] Motor Brake" in the contact output function of the parameter 12.

P13.00 M1 Locked State UP_ Reference**P13.01 M1 Locked State DOWN_ Reference****P13.02 M1 Brake OPEN Current****P13.03 M1 Start Delay Time****P13.04 M1 Brake Close Speed Set****P13.05 M1 Brake Open Torque Build Time**

- Output Speed (Frequency) > P13.00(forward), P13.01(reverse)
- Output Current > P13.02
- Taking time after inputting RUN signal > P13.05

Once three conditions above are met, a contact output is generated to control the

brake of the motor. When the elapse time after the contact output has become the set value of P13.03, the speed or frequency reference are increased, and then the motor speed (frequency) is increased. Refer to the figure 8.2-12.

If an output speed (frequency) is below the set value of this parameter, the contact output signal for controlling the brake is off, and it lets the brake be closed. Refer to the figure 8.2-13.

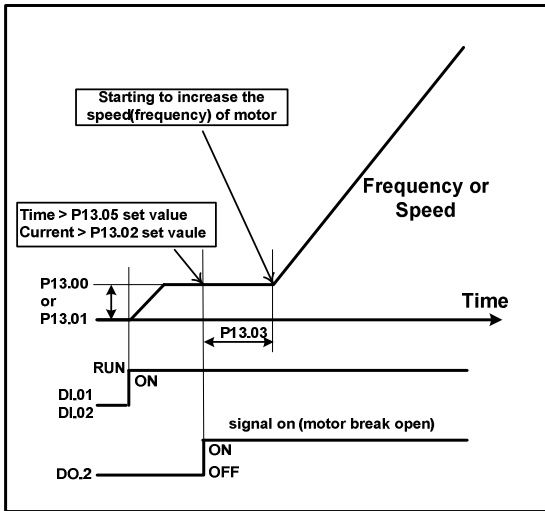

Figure 8.2-12 Motor Brake On-signal

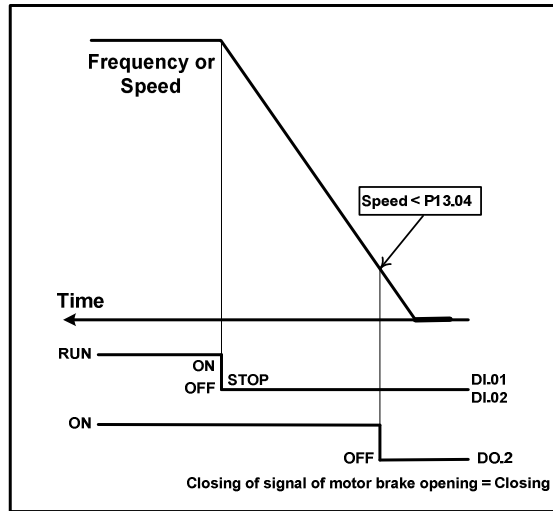

Figure 8.2-13 Motor Brake Off-signal

8.2.14 Parameter Group 14 : Auto Tuning Configuration

It is the parameter that sets necessary details for Auto Tuning.

P14.00 Motor tuning Condition

It is a precondition for auto tuning a motor.

[1] **Free Rotor** : In the state that the motor has no any load or brake of motor is available to open.

[2] **Locked Rotor** : In the state that the motor has a load or brake of motor is unavailable to open.

P14.01 Excitation Slip Frequency

Set up a slip frequency for motor tuning while the motor is stalled. Mark this with the percentage of a rated slip frequency.

P14.02 Min. Tuning Speed

Set up the minimum tuning speed in case of operating Speed Tuning

P14.03 Max. Tuning Speed

Set up the maximum tuning speed in case of operating Speed Tuning

P14.04 High Frequency Excitation Frequency

P14.05 High Frequency Excitation Current

- P14.06 Starting Excitation Current**
- P14.07 Low Speed Excitation Flux**
- P14.08 Low Speed Excitation Frequency**

8.2.15 Parameter Group 15 : V/F Control [Motor 1]

These are the V/F Control parameters for Motor 1.

P15.00 Torque Compensation

This parameter sets up the Torque Compensation Method in low frequency.

If the V/F Control is used, torque generation is compromised, so sets up a torque compensation method to compensate. This feature can improve the ability to produce torque, especially in low speed areas.

[0] Manual : Manual Torque compensation selection

The output voltage is generated for compensation depending on the following parameters: P15.06, P15.07, P15.08, P15.09, P15.10, and P15.11.

[1] Auto : Automatic Torque Compensation selection (Recommended)

The output voltage for compensating torque is generated automatically depending on the load. In this case, only excitation current is generated. The output current is increased if the load is increased. The parameters that are related to the Manual torque compensation would be ignored excepting P15.11 Maximum output voltage.

P15.01 Min. Output Frequency

Set the minimum operating frequency.

P15.02 Max. Output Frequency

Set the maximum operating frequency.

P15.03 Torque Compensation Flux Current

Set up the Flux Current at DC(0 Hz) if P01.06=[1] V/F Speed Control or P15.00=[1] Auto Compensation is used.

P15.04 Torque Compensation Time Const

Sets up the Torque compensation time constant if P01.06=[1] V/F Speed Control or P15.00=[1] Auto Compensation is used.

P15.05 Speed Detection Time Constant

Sets up the time constant for detecting a motor speed if P01.06=[1] V/F Speed Control is used.

P15.06 V/F Pattern

Set up the output voltage curve for the inverter output frequency

[0] Linear V/F Curve

It is used for the application of a constant torque. The inverter output voltage, from the speed of zero to the field weakening point, changes in proportion to the output frequency. Refer to the Figure 8.2-15.

[1] Square V/F Curve

The output voltage, from the speed of zero to the field weakening point, changes into a square-law reduced curve for the output frequency. It is used for the square-law reduced load like a fan or pump and etc. Refer to the Figure 8.2-15.

[2] Custom V/F Curve

The user's random curve can make a V/F curve appointing three points by user's own desire. Refer to the Figure 8.2-14.

[3] Free Function

Figure 8.2-14 V/F Pattern

P15.07 Zero Frequency Voltage

Set up the output voltage at 0Hz if P01.06= [0] V/F Freq (V/F Frequency Control) or P15.00= [0] Manual (Manual Compensation) is used.

P15.08 Mid Frequency

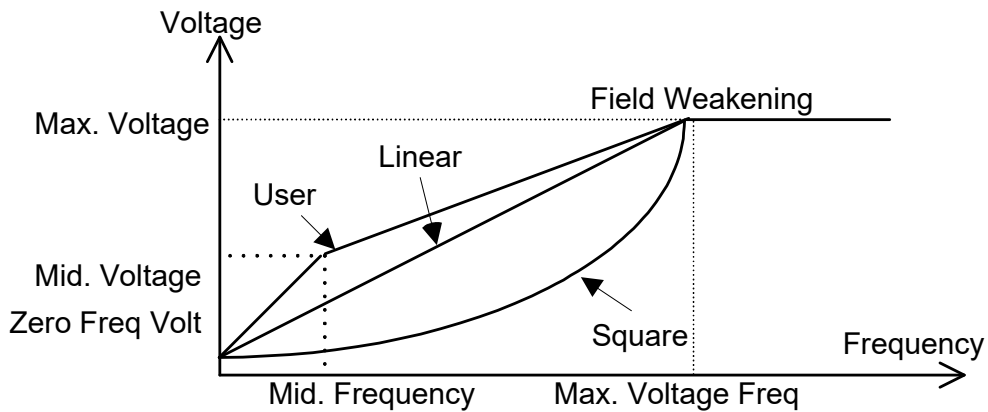
Set up the mid-point frequency when using the user's random curve if P01.06= [0] V/F Freq (V/F Frequency Control) or P15.00= [0] Manual (Manual Compensation) is used.

P15.09 Mid Frequency Voltage

Set up the output voltage at the mid-point frequency when using the user's random curve if P01.06= [0] V/F Freq (V/F Frequency Control) or P15.00= [0] Manual (Manual Compensation) is used.

P15.10 Max Voltage Frequency

Set up the frequency of which the maximum voltage is generated if P01.06= [0] V/F Freq (V/F Frequency Control) or P15.00= [0] Manual (Manual Compensation) is used.

P15.11 Max Output Voltage

Set up the inverter output voltage in a frequency range of field weakening operation if P01.06= [0] V/F Freq (V/F Frequency Control) or P15.00= [0] Manual (Manual Compensation) is used..

P15.12 Voltage Limiter

[0] Disabled

The output voltage can be generated as long as the output voltage allows the input voltage. Limit is eliminated.

[1] Enabled

The output voltage does not generate output more than the value set in P15.11 Max. output voltage. Limit is set.

8

P15.14 Square Curve Voltage Compensation

During the initial operation of the motor, the square curve characteristics are raised compared to the reference. (e. g. Fan, pump)

P15.15 Start DC Brake [Time]

Set up the time that generates braking current when starting

When this parameter is set to 0, there will be no braking current when starting.

P15.16 Start DC Brake [Blank time]

Set up the acceleration time of braking current when starting.

In case that there is braking current during the high-speed rotation, inverter can generate the excitation current without an inverter trip for the set time.

P15.17 Start DC Brake Current [START]

Set up the amount of braking current to output when starting. (100% = P01.02)

P15.18 Stop DC Brake Time [STOP]

Set up the time that generates the braking current when stopping.

The set time is the sum of the 1 second that DC braking current is generated during stopping of P15.21 and the time that P15.20 DC braking current is generated. If the time sets less than 1 sec, only P15.21 occurs. There will be no braking current if this is set to 0.

P15.19 Stop DC Brake Blanking Time [STOP]

Set up the acceleration time of the braking current when stopping
In case that the braking current is generated during the high-speed rotation, inverter can generate the excitation current without an inverter trip during the set time.

P15.20 Stop DC Brake Hold Current [STOP]

Set up the DC braking current amount that DC braking current is generated when stopping and is maintained from after 1 sec.

P15.21 Stop DC Brake Starting Current [STOP]

Set up the amount of the DC braking current when stopping of P15.21. (100% = P01.02)

It is occurred for 1 sec. after the speed(frequency) order value of inside of inverter is 0.

8

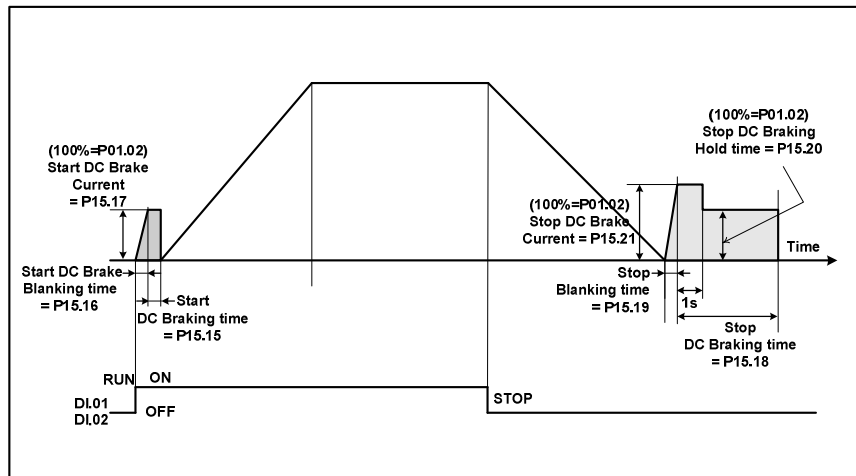

Figure 8.2-15 Set up DC Brake

P15.24 Stabilization Time Const

Set up the stabilization time constant for the stabilization controller.
 The stabilization controller can reduce the resonance of motor or other unstable problems, which is automatically detected by the stabilization controller.

P15.25 Stabilization Gain

Set up the Gain of the stabilization controller

P15.26 Stabilization Limit

This sets the upper limit of control output for the stabilization controller. If the resonance of motor or other unstable problems is not removed entirely, increase this value to remove the problems.

P15.27 Unity Current Range: Freq

Set up the frequency of which the current controller starts to change in the range of

field weakening operation. It is set automatically if you operate the auto-tuning function. This is used when the operation is in high speed over the rated frequency, and this parameter is for controlling smooth current in high speed range.

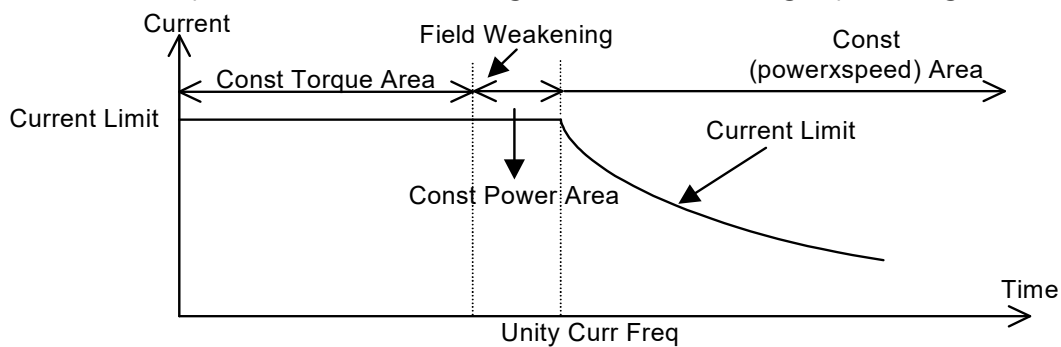

Figure 8.2-16 Operating unite current range

P15.28 Over Current Control Gain(Accelation-acceleration or crusing)

P15.29 Over Current Control Gain(Decelation)

The inverter reduces the output frequency when the output current become over the Current Limit during acceleration/deceleration or crusing. This allows you to increase the output frequency without exceeding the Current Limit. P15.28 and P15.29 set the slope of decrement.

8.2.17 Parameter Group 17 : Sensor less Vector Control [Motor 1]

These are Motor 1-parameters for operation of S/L Vector control.

P17.00 Speed Detection time

Set up the time constant for speed detection

P17.01 Min. Speed

Set up the minimum operation speed

P17.02 Max. Speed

Set up the maximum operation speed

P17.03 Over Speed Limit

In case that the estimated motor rotational speed exceeds the set value, the inverter output is immediately cut off and display the fault signal.

P17.05 Starting Flux

Set up the amount of flux to be applied from the speed of zero to the speed of Par.17.07

P17.06 Base Flux

Set up the amount of flux to be used from the speed of Par.17.08

P17.07 Start Flux-END Speed

The flux of Par.17.05 is applied to the speed from zero to Par.17.07.

The start flux-end speed is set in the percentage of the maximum speed. (Par.17.02)

P17.08 Base Flux-START Speed

Set up the speed of which the flux of Par.17.06 starts to be applied

The base flux-start speed is set in the percentage of the maximum speed. (Par.17.02)

P17.09 FW Voltage

This parameter sets the electromotive Force (EMF). If this value is too high, the output voltage becomes increased in the field weakening area, and if the value is too low, the output voltage becomes decreased in the field weakening area. If this value is over than 100%, the condition of torque control cannot be good because there might be not enough voltage for operating the current controller. In that case, reduce the value if the motor cannot run up to the maximum set speed.

P17.10 FW Profile Time Const (Field Weakening Time Constance)

Set up the time constant for the flux changes in the field weakening operation.

P17.11 CC P-Gain Scale

Set up the scale in percentage of P-Gain of the current controller that is gained from auto tuning.

P17.12 CC I-Gain Scale

Set up the scale in percentage of I-Gain of the current controller that is gained from auto tuning.

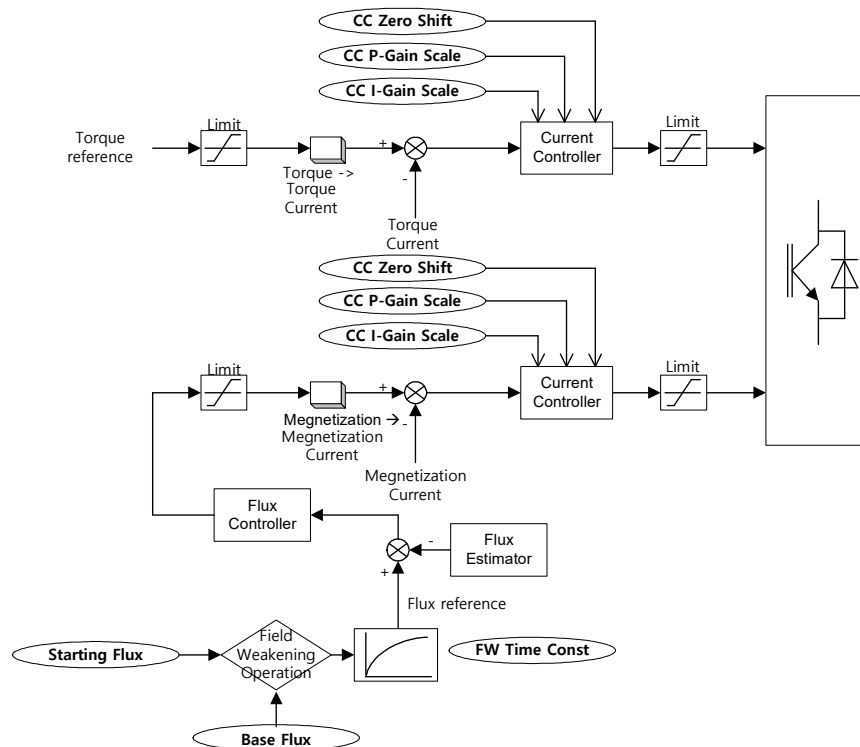

Figure 8.2-17 Sensorless vector control block

P17.14 Speed PI Gain

In order to set the P, I Gain to be used for the speed controller, apply the set gain as a fixed value or use the gain that is set automatically by auto tuning.

[0] Default (Default Gain)

[1] Result by Auto-Tuning (Auto-Tuning Gain)

P17.15 Load Observer Activation

Decides the usage of Load Observer.

P17.16 Load Observer Time Constant

Set up the time constant of Load Observer.

P17.17 Load Compensation Start Frequency

Set up the minimum frequency of Load Observer operation.

P17.18 SC P-Gain

Set up the P-Gain of speed controller by auto tuning in percentage.

P17.19 SC I-Gain

Set up the I-Gain of speed controller by auto tuning in percentage

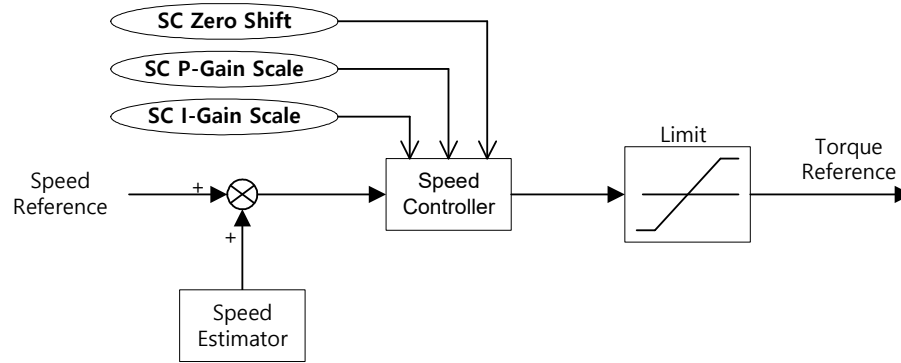

Figure 8.2-18 Speed Control Block

P17.20 SC Ref Weight Factor

It moves a point of zero of PI controller in speed controller to the high frequency band, and reduces the speed overshoot.

8

P17.25 ~ P17.49

Don't change anything users own option. If you need to change things, please contact us.

8.2.21 Parameter Group 21 : Motor 1 Parameter

This parameter is automatically set by Motor 1 Auto-Tuning.

P21.00 Stator Resistance 1

Set up the stator resistance 1 of a motor

P21.01 Stator Resistance 2

Set up the stator resistance 2 of a motor

P21.02 Rotator Resistance

Set up the rotator resistance of a motor

P21.03 Stator Inductance

Set up the stator inductance of a motor

P21.04 Rotor Inductance

Set up the rotor inductance of a motor

P21.05 Leakage Inductance

Set up the leakage inductance of a motor

P21.06 Inertia Time Constant

Time to the rated speed with rated torque.

P21.07 Iron Loss Compensation

An iron loss impacts on the efficiency of control in the high-speed section. It can reduce controlling efficiency due to the compensation for excessive loss or lack of loss. You can improve its function through adjusting the amount of iron compensation.

P21.08 Biscos Damping Efficient

8.2.24 Parameter Group 24 : Monitor Setup

P24.02 Key Repetition Time

The reaction time of a keypad's button

P24.03 Speed Monitor Selection

[0] Calculation

The motor rotation speed that is displayed on a keypad indicates the calculated speed.

[1] Pulse Generator

The motor rotation speed that is displayed on a keypad indicates the actual rotation speed gained from encoder.

P24.04 Speed Detection time Constant

In case of that the Speed Monitor Selection is set to Encoder, and this sets up the filtering time when measuring a motor speed from encoder.

P24.05 Monitor Filter Time Constant

Set the Filtering Time for the Keypad display values

P24.06 Previous Run Direction

[0] Forward (Upward)

[1] Reverse (Downward)

P24.07 Previous Speed Set

P24.08 Previous Frequency Set

P24.09 Previous Torque Set

P24.10 Previous PID Set

P24.12 Default Monitor Item

When inputting the main power to the Inverter, set the monitor items displayed initially on the keypad.

- [0] Dc_Bus Voltage
- [1] Line Voltage
- [2] Line Frequency
- [3] Line Current
- [4] Active Power
- [5] Reactive Power
- [6] Power Factor

P24.13 Left/Right Button Speed Set [Hz]

P24.14 Left/Right Button Speed Set [rpm]

P24.17 Accumulation Running Time [10 hours unit]

Accumulated operation time in 10 hours unit when inverter operation.

P24.18 Accumulation Running Time [1 hour unit]

Accumulated operation time in 1 hour unit when inverter operation.

P24.19 Accumulation Running Time [1 minute unit]

Accumulated operation time in 1 minute unit when inverter operation.

P24.20 Accumulation Running Time [1 second unit]

Accumulated operation time in 1 second unit when inverter operation.

9. Protection

9.1	Warning	9-1
9.2	Parameter Error	9-2
9.3	Parameter Fault	9-2

9. Protection

9.1 Warning

State	Indication	Type	Specification
Warning ERR [Warning]	E01	Under Voltage	If DC_Link Voltage is lower than the "Under-Voltage limit" (P05.18), the warning occurs.
	E02	Over Voltage1	If DC_Link Voltage exceeds the Over-Voltage limit (P05.15), the warning occurs (Software manages).
	E04	Sensor Error	It happens when there is a problem of current sensor & circuit.
	E05	Over Load	This occurs if the output current satisfies the over-load condition of P05.08 and P05.09. If P05.10=[3] ignore, it doesn't occur.
	E06	Zero sequence current	There is a detection of current leakage that exceeds P05.12.
	E07	Over Temperature	It happens when the temperature of heat sink of inverter exceeds 90°C.
	E08	Device Short	It happens when there is a problem with a switching device of inverter.
	E09	NC Drive Disable	It happens if there is no "Enable" input signal from the digital input terminal when Digital Input function is set to "Drive Enable".
	E14	Drive Calibration Disorder	It occurs after parameter initialization or changing switching Frequency. Execute "[0]Drive Calibration" of "A3-Auto Tuning"
	E16	Drive Cooling	In case of P05.25=[0] or [1], the temperature of the inverter heat sink exceed 90°C.
	E17	Auto Tuning Failure	If fault occurs after an attempt to auto-tuning or drive calibration: Check motor and wiring
	E18	Motor Brake not open	If the digital output function is set to [4] Motor Brake, the inverter operation conditions are not satisfied under the brake opening conditions of P13.00~P13.04(P13.06~P13.10)
	E19	External Fault	It happens when a digital input function is set to [10] External Fault (A) and [11] External Fault (B), when a signal is entered at that digital input terminal.
	E21	Over Voltage Limit	It happens if P05.13=[1] and P05.21 = [1]. The warning is removed when the set value for P05.14 is higher than the set value in P05.24.
E31	UV Limiting	Warning that occurs when operating inverter	

<Next>

<Continued>

State	Indication	Type	Specification
Warning ERR [Warning]	E32	OV Limiting	Warning that occurs when operating inverter
	E33	OC Limiting	Warning that occurs when operating inverter
	E34	OT Limiting	Warning that occurs when operating inverter

9.2 Parameter Error

State	Indication	Type	Specification
Parameter Err ERR[Pxx.xx] Parameter Combination err ERR[Parameter]	PE-00	Parameter Damage	A flash memory of parameter is damaged.
	PE-01	Output power, Voltage Setting Err	Setting error of rated output, rated voltage, and rated current of the motor
	PE-02	Frequency Setting Err	Setting error of rated frequency and rated speed of the motor
	PE-03	NC Capacity Setting Err	Setting error of checking inverter power
		Parameter setting Err	In case of parameter setting error, the corresponding parameter number is displayed. (ex: P02.01 displayed for P02.01)

9.3 Parameter Fault

State	Indication	Type	Specification
Control Fault ERR[Control]	F01	Over Load	It happens when output current of inverter meets Over Load condition of P05.08, P05.09.
	F02	Over Current [S]	It happens when output current of inverter exceeds the set value of P05.11. (Software manages.)
	F04	Zero-sequence current [S]	It happens when Zero-phase-sequence current exceeds the set value of P05.12.
	F07	Over Voltage [S]	It happens when DC_Link voltage of the inside of inverter exceeds the set value of P05.15. (Software manages.)

<Next>

<Continued>

State	Indication	Type	Specification
	F09	Under Voltage	It happens when DC_Link voltage of the inside of inverter is lower than the set value of P05.18.
	F10	Over-speeding Motor	Occurs when the motor rotation speed exceeds the speed set in P17.02.
	F11	Out of Control	It happens when a control condition is not good due to internal and external factors; when a brake is not released; when a load is extremely big; when an input signal does not go into the encoder.
Drive Fault ERR[Operation]	F21	Overheated Inverter	If the output frequency exceeds by 45Hz and the heat sink exceeds temperature by set in P05.40 the fault occurs. If the output frequency is less than 45Hz, overheat detection value of inverter is changed by the output current and output frequency. It's necessary to keep watching the output frequency, current and temperature when a fault occurs.
	F22	IGBT/MOTOR Device Short	It happens when there is a problem with a switching device of inverter(IGBT) and motor device short.
	F24	Dynamic Brake Chopper (DBR) Damage	It happens when DC link voltage does not go up due to a problem of built-in Brake Chopper or DBR after you turn on the power. And it also happens when over current occurs or a device is damaged while Brake Chopper is at work.
	F25	Signal Input of External Fault	It happens when a Fault signal is inputted from external device.
	F27	Open phase Fault	It happens when one of phases is broken or cut.
	F28	Motor is in a stall status	It happens when the brake of motor is not opened.

<Next>

<Continued>

State	Indication	Type	Specification
Auto Tuning Fault ERR[Tuning]	F41	Motor Connection Fault	It happens when a connection between inverter and motor is separated.
	F42	Motor Tuning Error 1	Error occurred in equivalent resistance value obtained during motor tuning.
	F43	Motor Tuning Error 2	Error occurred in equivalent inductance value obtained during motor tuning.
	F44	Motor Tuning Error 3	Error occurred in stator resistance value obtained during motor tuning.
	F45	Motor Tuning Error 4	Error occurred in rotor resistance value obtained during motor tuning.
	F46	Motor Tuning Error 5	Error occurred in stator inductance value obtained during motor tuning.
	F47	Motor Tuning Error 6	Error occurred in rotor inductance value obtained during motor tuning.
	F48	Motor Tuning Error 7	Error occurred in inertia value obtained during motor tuning.
	F49	Motor is in a stall status	It happens when tuning condition P14.01 is set to be large.
	F50	Auto Tuning Time Over	It happens when Auto Tuning time is over.

10. Troubleshooting

10.1	Troubleshooting	10-1
10.2	Maintenance and Inspection	10-3

10. Troubleshooting

10.1 Troubleshooting

Condition		Check items	Management
When there is no rotation of motor	Inverter output does not occur.	Does the input voltage of inverter work properly?	Check the input voltage of inverter (L1, L2, L3)
		Is the KEYPAD of inverter on?	Call an agent when inverter does not get turned on, even though a contact of KEY PAD is OK
		Is the operation mode & Reference of inverter properly set?	Check a set value of parameter
		Is an operation signal inputted to the inverter?	Check if an operation signal is properly inputted
		Is a speed signal 0?	Check the connection of speed signal and the change of the signals at the terminal
		Did several warnings or faults occur?	Rerun after you release warnings and faults
	Inverter output occurs.	Is a motor properly connected?	Connect the inverter output U, V, and W to the motor input U, V, and W for each phase
		Is a motor stalled or is a load big?	Release or reduce a load
		Check if a Brake properly works when it is attached to a motor	Open a Brake and then operate
	When there is no rotation of motor	Inverter output does not occur.	Check if an open-phase occurred to a motor
Is an output current of inverter equal to, or bigger than a set limit of current?			Check if a parameter setting is right and then increase speed by extending accelerating time
When a motor rotates in the opposite direction		Is an inverter output of U, V, and W in its right place respectively?	Change the terminal location of V phase and W phase
		Are the forward and reverse operating signals connected properly?	Change the location of the forward and reverse operating signals.
A speed does not increase		Isn't a load big?	Release or reduce a load Extend an accelerating time
A speed does not decelerate smoothly		Is a resistor connected to inverter?	Connect a resistor to inverter
		Isn't a deceleration smooth even though a resistor is connected?	Extend a decelerating time

<Next>

<Continued>

Condition	Check items	Management
When a current of motor is big	Isn't a load big?	Release or reduce a load
	When a load is big, isn't the Main Input voltage getting reduced?	Check the input voltage of the inverter
	Is there any factor that stalls motor?	Get rid of stall factor
	Is an Auto-Tuning properly operated?	Rerun Auto-Tuning
	Does a current of motor resonate?	Reset a parameter
	Is a load unsettled?	Recalculate the power
	Does a speed signal change?	Settle a speed signal

※ 0.75kW~ 3.7kW NC Inverter models display fault on LED screen.
 (WARNING didn't show up on LED screen)

10.2 Maintenance and Inspection

Checking part	Check list	Checking item	Checking period		Checking method	Criterion
			Daily	Regular interval		
General matter	Surroundings	Check an ambient temperature, humidity, dust, harmful gas, oil remnants, and etc.	○		Check an ambient temperature, humidity, dust, harmful gas, oil remnants, and etc.	The ambient temperature should be -10~40°C. There should be no dewdrops in 20~90% RH of the surrounding humidity. (No condensation allowed)
	General device	Unusual vibration and sound	○		Unusual vibration and sound	There should be no problem.
	Power supply voltage	Check if a voltage changes or is low	○		Check if a voltage changes or is low	It should not exceed ±10% of the rated voltage.
Main Circuit	General matters	Insulation resistance		○	Use 500V-mega between main circuit terminal and earth terminal	There should be no problem.
		Check if a screw is loose		○	Check with your eyes	
		Check if there is a mark of overheating		○	Check with your eyes	
	Terminal Block	Damage		○	Check with your eyes	There should be no damage.
	Smoothing Condenser	Liquid leakage, Deformation	○		Check with you eyes and ears	
	Relay	Tremble		○	Check with your ears	
	Resistor	Crack, Discoloration		○	Check with your eyes	
	Cooling Fan	Vibration, abnormal sound	○		Check with your ears	
	Cooling Water System	Dust, dirt		○	Check with your eyes	
	Wire	Deformed, stripped		○	Check with your eyes	
Inverter Output	The 3 phase-output		○	Multi-meter Voltmeter	The 3-phase output has to be equal for each phase.	

	Motor	Vibration	○		Tightening	It should be fine.
					Output Current of inverter	The 3-phase output has to be equal for each phase.
		Overheating	○		Cooling FAN condition	There should be no disorder.
Control Circuit	Operation	Protective circuit		○	Operate of your own accord	There should be no problem.
	Connection	Tightening		○	Check with your eyes and hands	There should be no problem.
	KEYPAD	Indication, working condition		○	Check with your eyes and hands	There should be no problem.