

Medium-voltage Drives

FRENIC4600FM6e



Medium Voltage Drive

Our Medium-voltage Drives aim to protect the environment and create clean energy for everyone.

Founded in 1923, Fuji Electric is an internationally renowned major general industrial electronics equipment manufacturer, and our products are widely used in various fields such as power generation, iron and steel, oil & gas, mining, chemicals, cement, water plant.

Fuji Electric has continued its tireless efforts in the development and application of advanced power electronic technology that is a fusion of such fields as power semiconductors, microelectronic circuits, and automatic control systems. Since the 1980s we have been manufacturing and delivering to the world medium-voltage drives speed control devices for various types of load equipment drives. Among these, our FRENIC4600FM6e medium-voltage drive is a high-performance, high reliability medium-voltage drive speed control device.

A photograph of a modern, multi-story white building with large windows, identified as a Fuji Electric facility. The building is partially obscured by green trees in the foreground. The Japanese characters '富士電機' (Fuji Electric) are visible on the building's facade.

富士電機

Contents

Features	3	Standard interface and format description	16
Industrial applications	5	Selection of capacity	17
Simple circuit configuration	7	Substantial energy saving	22
Main circuit configuration	9	Abundant variations in the series	23
Functional description	11	Ordering information	24
Data setting and monitoring	13		
Standard specifications	14		
Standard connection diagram	15		



1 Substantial reduction of harmonic current on power source side

- A multi-phase diode rectifier system (18 to 54 phases) is used to suppress harmonics. Significantly less harmonics are generated than conventional models, and because the amount of harmonics generated is much lower than that specified in IEEE-519 (1992), this is an inverter that does not degrade the power supply.

Current waveform on power source side

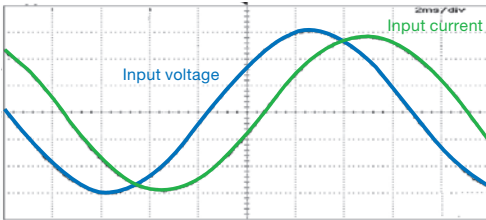

Harmonic current content

Order	5th	7th	11th	13th	17th	19th	23th	25th	35th	37th
IEEE value [%]	4.00	2.86	1.83	1.49	1.14	1.02	0.87	0.80	0.80	0.80
Measured value [%](*)	0.58	1.0	0.20	0.32	0.75	0.54	0.06	0.24	0.58	0.27

(*) Example value from our full load test

2 High efficiency: Total efficiency of approx. 97%

- Because an output transformer is unnecessary, inherent losses are eliminated.
- Use of our proprietary multi-level PWM control system reduces switching losses.
- Because the harmonic current on the power source side is reduced, the primary winding of the input transformer has a reduced loss due to the harmonics.

Total inverter efficiency curve (including input transformer)

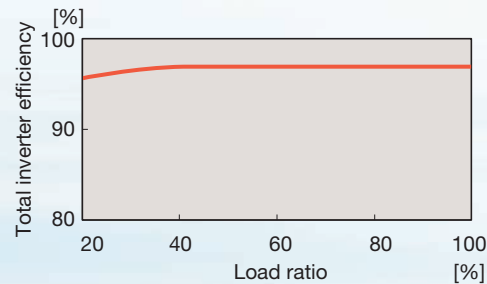

3 High power factor: Source power factor greater than 95%

- The use of a multi-phase diode full-wave rectifier increases the power factor on the power source side, enabling operation at a high power factor.
- A phase advancing capacitor and a DC reactor for improving the source power factor are unnecessary.
- A smaller power capacity suffices for inverter operation.

Source power factor curve

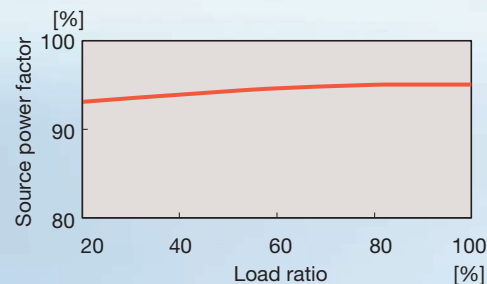



4 High reliability

- High-accuracy, rotation speed sensor-less vector control functions enable stable operation during load variations from low speed to high speed.
- World-class Fuji own brand IGBT cells, redundant bypass control technology, and multi-level fault alarm functions are employed to ensure very high reliability.
- A high-end 32-bit motor control MCU is employed in the control device for quick response and high accuracy.

5 Vector control

- Advanced and practical vector control technology is adopted for asynchronous and synchronous motors and achieves high-accuracy non-velocity vector control with a large starting torque, fast response dynamics and high load capacity.

6 Easy maintenance

- The inverter is air-cooled, requiring no cooling water.
- Start/stop operations, parameter setting, fault display, and data monitoring are easily performed on a touch panel with simplified input functions.
- A simple auto-tuning function for test adjustments facilitate adjustment.
- Fault diagnosis are easily performed.
- A dry-type input transformer is adopted.



Industrial applications

Cement

- Fans
- Kilns
- Separators
- Bucket elevators



Chemicals

- Granulators
- Compressors
- Fans and pumps



Water treatment

- Water plant





Iron and Steel

- Fans
- Induction blowers
- Dust collectors
- Cooling water pumps



Power generation

- Turbo refrigerators
- Banbury mixers
- Ball mills



Other industries

- Turbo refrigerators
- Banbury mixers
- Ball mills

Simple circuit configuration

The medium-voltage drives utilize internationally advanced electronics technology, and are equipped with a highly integrated motor control MCU and a multi-level cell tandem structure with an optimized design. There is no need for harmonic filters outside the rating or power factor correction capacitors. The reliability is very high, and these inverters are easy to operate and maintain.

Master control panel

- Equipped with an optimal 32-bit MCU for industrial motor control, and a voltage detection system utilizes a special ARM sampling platform. Boasting high-speed response and high control accuracy, also features short acceleration time to fluctuations in torque load, and acceleration with high control performance that will not allow overcurrent.
- Flexible interface enables easy operation by the customer. Made-to-order options tailored to the customer's needs are also possible.



Input multiplex winding transformer

- Harmonic current on the power source side is low due to a multiplex configuration of the secondary winding.
- With the use of a multi-phase rectifier (18 to 54 phases), harmonic current emissions completely satisfy the provisions of the IEEE. The installation of harmonic filters and power factor correction capacitors is not required.
- A dry-type transformer is adopted on the input side, and because the transformer is on the panel, there is no external connection work required for the cable between the transformer and the inverter panel.
- Since the dry-type isolated transformer is an integrated design, the electric motor is protected, making it easy to install and reducing the installation costs.



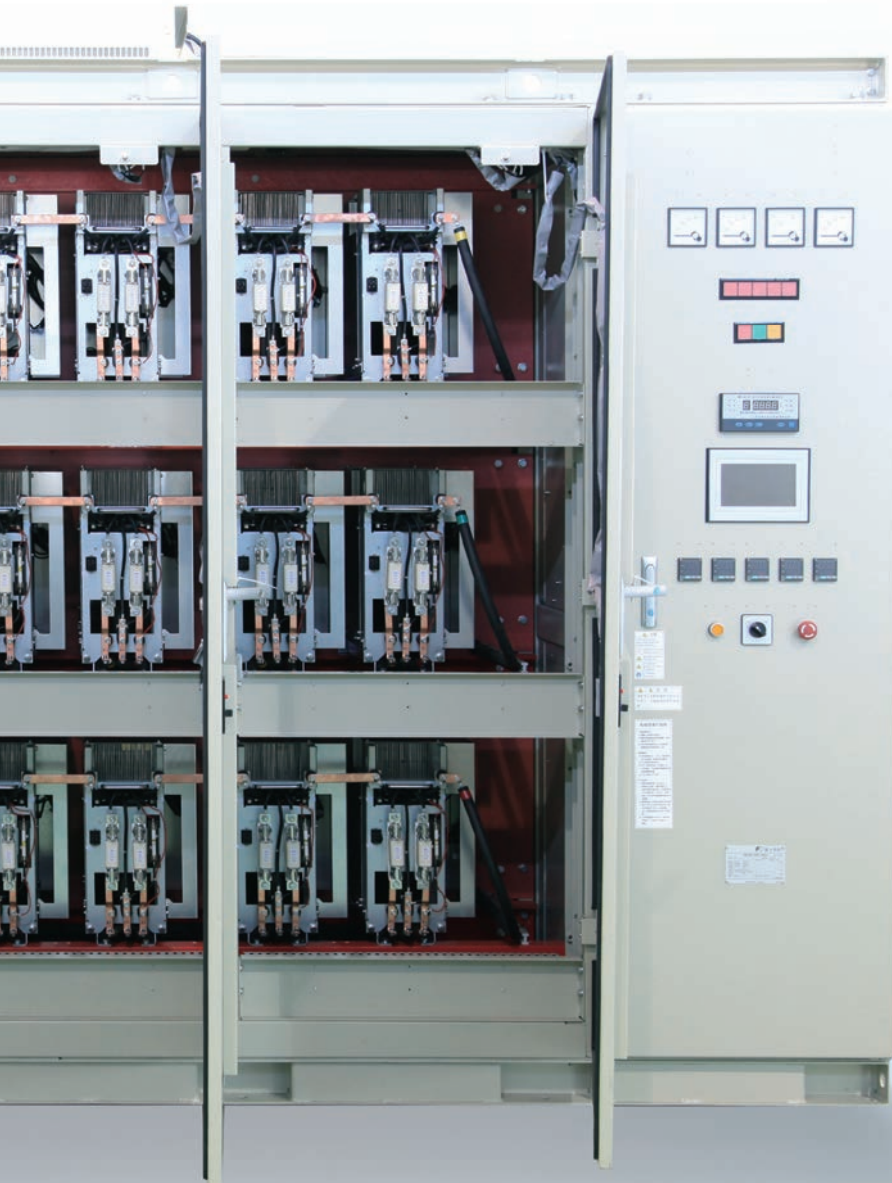

Cooling fan

- Air-cooled inverters make maintenance easy.



Inverter cell

- The stability of the system is further improved with the use of a cell tandem phase structure equipped with a cell intelligent bypass function.
- Each inverter cell alone can be taken out and replaced easily, because the controller, diodes, IGBT elements and DC intermediate capacitor are combined into an integral body.
- Utilizes the latest Fuji 1700 VAC medium-voltage IGBT with the world's top-class delivery track record, and boasts high reliability.

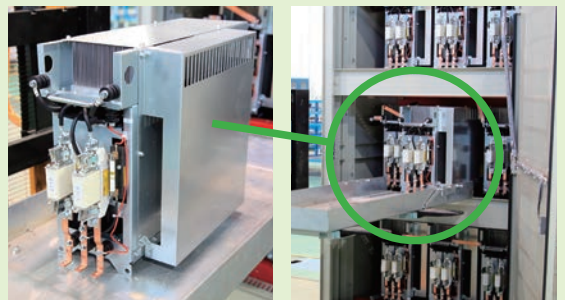

Main circuit configuration

Main circuit configuration diagram

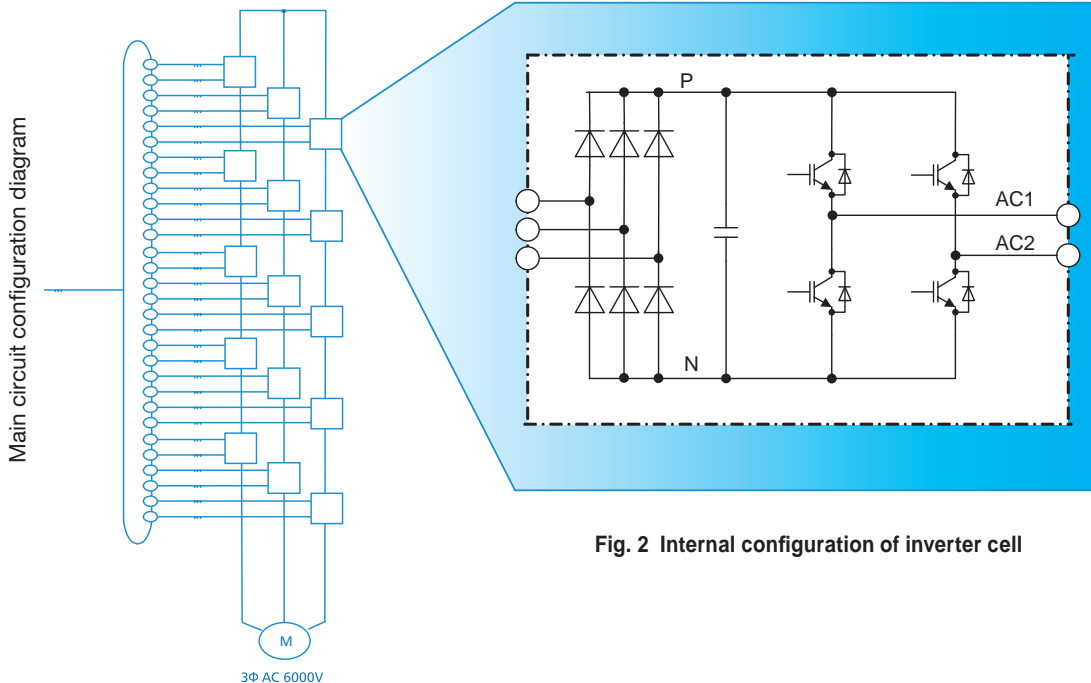

Fig. 2 Internal configuration of inverter cell

Fig. 1 Main circuit configuration diagram of 6 kV type

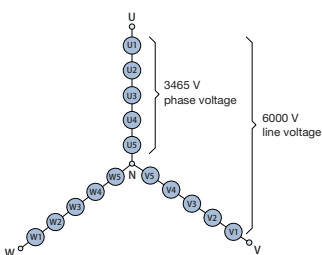

Fig. 3 6 kV configuration

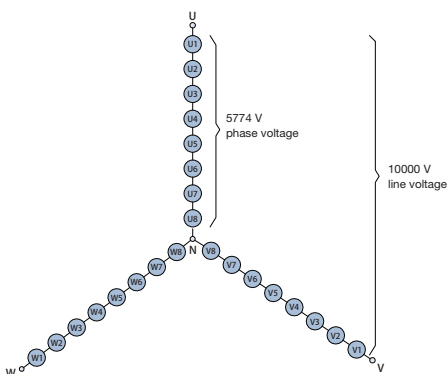

Fig. 4 10 kV configuration

- The inverter configuration is as shown in Figure 1. A 6 kV class inverter comprises the input transformer and 15 inverter cells. (A 10 kV class inverter is composed of 24 inverter cells.)

- Each inverter cell consists of one single-phase two-level inverter which yields an output voltage of 693 V. As shown in Fig. 3, when a 6 kV class five inverter cells are cascade-connected to each phase, the phase voltage is approximately 3465 V. With a three-phase star connection it is possible to obtain a line voltage of approximately 6000 V.

- As shown in Fig. 4, when a 10 kV class eight inverter cells are cascade-connected to each phase, the phase voltage is approximately 5774 V. With a three-phase star connection it is possible to obtain a line voltage of approximately 10000 V.

Friendly to machines

If a harmonic current component is contained in the inverter output current, a torque ripple occurs on the output shaft of a motor. A torque ripple means a change in rotational speed or a large vibration if the frequency of the torque ripple matches the natural frequency of the mechanical system and torque ripple is large.

In FRENIC4600FM6e, the harmonic component on the output side is extremely small due to the multi-level PWM control and the main component of torque ripple is at around the carrier frequency (several kHz). Therefore, torque ripple hardly affects the machine side.

Friendly to motors

- The multi-level PWM control provides an almost sinusoidal output current waveform, thus reducing motor torque ripple.
- The output current waveform is nearly sinusoidal, reducing the harmonic losses of the motor.
- The multi-level PWM control minimizes switching surge voltage and thereby reduces stress on the motor.
- There is no need to reduce motor capacity due to inverter drive.
- There is no need for special cables, etc. due to inverter drive.
- This inverter is applicable not only to a square-law reduced torque load, but also to a constant torque load such as an extruder.
- For driving a large-capacity motor in a system that has a small power capacity, voltage fluctuation, etc. due to the starting current of a motor will cause problems. However, because the starting current can be suppressed by the soft start of this inverter, operation can be performed.

— : output voltage waveform — : output current waveform

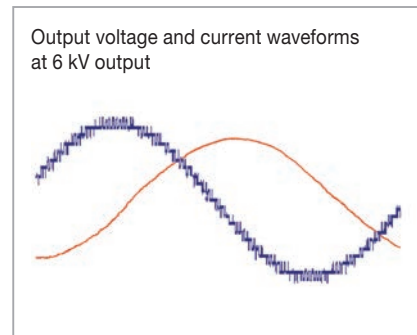
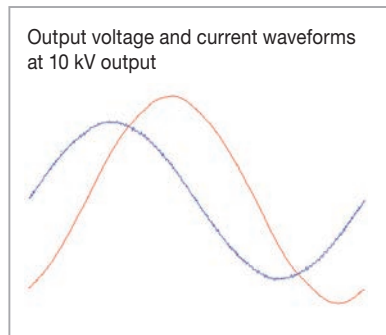

Note

Surge voltage and multi-level output

The output voltage waveform of a PWM inverter is a DC chopping voltage (called "pulse voltage = surge voltage") whose amplitude is determined by voltage E_d of the DC intermediate circuit.

When this surge voltage of inverter output is applied to a motor through a cable, the voltage is reflected repeatedly between the motor terminal and inverter terminal. A sharp overvoltage higher than the inverter output voltage is thus generated at the motor terminal, which may cause dielectric breakdown of the winding.

The multi-level PWM control of Fuji medium-voltage drives makes it possible to suppress the DC intermediate voltage, and effectively controls the overvoltage generated at the motor terminals.

Output voltage waveform (17 levels) in 10 kV class

In the 10 kV class Fuji Electric's medium-voltage drives, the output voltage changes in 17 steps (corresponding to 17 levels) within 1/4 cycle. The voltage value of one step equals the DC intermediate circuit voltage E_d . Therefore, for the same voltage output, a larger number of steps means a smaller voltage value at one step.

Thus, Fuji Electric's inverter can also reduce the surge voltage appearing at the motor terminal and thereby moderate the stress applied to the motor.

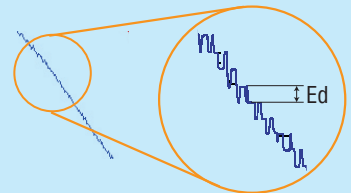

Synchronous motor vector control device (option)

At the core of the FRENIC4600FM6e inverter is a high-speed MCU, which is equipped with a vector control program that is internationally advanced and comprises a high-performance controller platform. The device will adapt to the advanced requirements of frequent start-ups and rate adjustments.

Main capabilities:

- Slow startup torque is large, with fast torque reaction during high speeds.
- Equipped with an electric motor rotor positioning function for the smooth start-up of synchronous motors.
- The inverter can automatically adjust the excitation current, enabling high system efficiency.

Cell automatic bypass function (option)

- When the cell automatic bypass function is selected, failures due to shutdowns are significantly reduced, greatly improving the reliability of the equipment.
- The FRENIC4600FM6e can accurately grasp the location of the failure point, and bypass the failed cell.
- The bypass control is completely separated from each of the power cells, and the FRENIC4600FM6e can automatically bypass a failed power cell within 0.5 seconds.

Description of instantaneous power failures

- It is possible to select the combined operation mode to use in the event of an instantaneous voltage drop.
 1. Select instantaneous voltage drop as a major fault
The inverter performs a major fault stop, and the motor will be in a free-run state.
 2. Selection of free-run restart (option)
The inverter stops operating, and the motor will be in a free-run state. When the power supply power recovers, the speed search function will automatically re-accelerate the motor that is decelerating in the free-run state or if the motor has already stopped.
 3. Selection of continued operation when an instantaneous voltage drop occurs (option)
If the motor does not enter the free-run state when an instantaneous voltage drop occurs, the inverter can operate continuously. After the recovery of the power supply voltage, the motor will be promptly re-accelerated and return to the operating speed.

Fig. 1 Continuous operation process

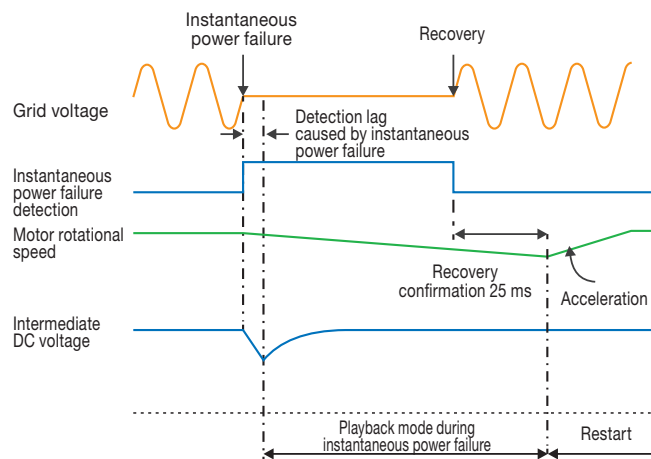

Note 1) When the instantaneous voltage drop is below 65% of the rated voltage. Note 2) The instantaneous voltage drop duration is less than 300 ms. (option)



Control functions

The FRENIC4600FM6e medium-voltage drives is equipped with 32-bit RISC processors for each of the CPUs used for the basic controls such as frequency control, operation programs, and various interfaces; for the high-speed computing used for the current control; as well as for the voltage processing and output voltage pulse waveform processing.

To enable combined optimal control for various applications, FRENIC4600FM6e have integrated the following functions in the internal system.

1 Logic functions

- In accordance with external logic and control signals, the system is operated and stopped by software.

2 Adjustment functions

- Based on the sampling control principles, FRENIC4600FM6e have achieved an optimal adjustment control.

3 Control parameter setting functions

- Each of the control parameters of the system can be set and optimally adjusted from the operation panel, keypad, HMI or centralized monitoring system.

4 Fault detection functions

- When faults occur, they can be displayed and verified using the operation panel, HMI, keypad or centralized monitoring system.
- In addition, tracking backup data can be collected before and after the fault using the keypad or centralized monitoring system.

5 Independent operation functions

- Can control operation of the FRENIC4600FM6e with no need to connect to the DCS.
- The operation methods include communications, external input access operations, analog command operations, and operations panel operations.

6 Power failure protection functions

- Power failure processing is performed when a power outage failure occurs. Data in RAM (built-in memory) is backed up by the capacitor, and one week of data can be preserved even in a non-energized state.
- In addition, setting data in non-volatile memory (flash memory), is backed up even in a non-energized state, and setting data is not lost.

7 Online, analog quantity data output

- During operation, the related data can be output in analog mode.

Data setting and monitoring

Very easy operation and monitoring using the 7-inch color LCD operation panel

Setting

Setting, change and display of control parameters

DIO display, AIO display

Display input and output state and functional distribution information

Actual value display

Display each actual value of the inverter (frequency command, voltage command, current value command, current detection, etc.)

Monitoring device

Control each actual value of the inverter as displayed on a block diagram

Transmission screen

Display state of transmission and input-output numerical values

Fault screen, fault history

Display fault (major, medium, minor fault) generation time and cause of fault
Check up to 100 previous faults in the history

Trip data

Display the data for each component at time of fault

Accessory functions

Set the internal time, check the status of the inverter

Automatic adjustment

Automatically adjust the motor

Log out

Monitor the screen, but parameters can not be changed

Operation screen and start-up conditions

Confirm frequency settings and operating conditions (satisfied, not satisfied)

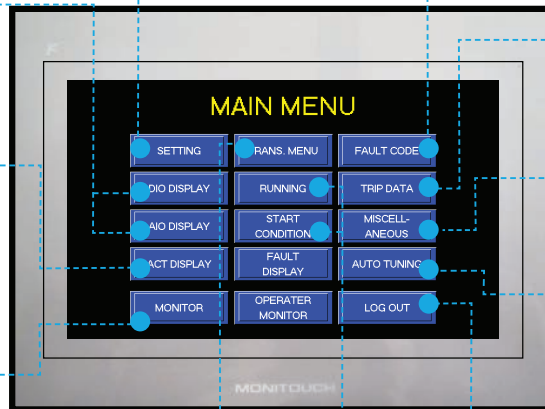

Example of display screen

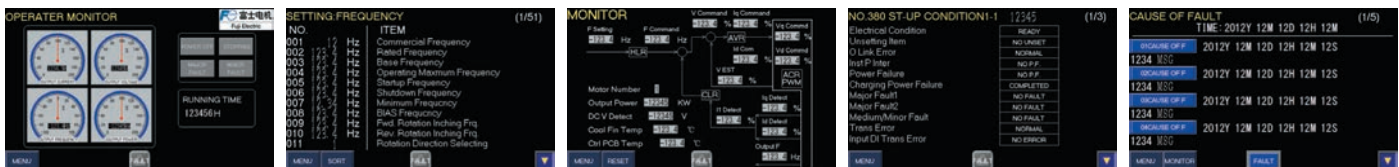

Operation screen

Setting screen

Monitoring screen

Start-up condition screen

Fault history screen

Operation panel display contents

No.	Description	Number of items
1	Current, voltage and frequency at present (*)	7
2	Parameter setting items	About 320
3	Di/Do status display	7
4	Controller RAM data	About 80
5	Ai/Ao status display	11
6	Sent/received data	About 20
7	Cause of fault	20
8	Present time, operation time	3

(*): Displays 7 items on the 2-image screen.

Other functions

Fault history

Displays a chronological record of 100 faults with the cause and the date and time of occurrence.

Trip data display

Displays the sampling values of internal data and bit data ON/OFF status in the event of a fault.

Save of set data, load, and comparison

The set data can be saved in the EPROM of the operation panel. The saved data can also be loaded and compared with other saved data.



Inverter standard specifications

Inverter model number		FRENIC4600FM6e
Input	Main circuit	Three-phase, 3000, 3300, 4160, 6000, 6600, 10000, 11000 VAC, 50/60 Hz
	Control circuit	Single-phase, 220 VAC 50/60 Hz
	Fan power supply	Three-phase, 380 VAC 50/60 Hz
	Allowable power variation	Voltage: -35% to +10%, Frequency: $\pm 5\%$
Control	Control method	V/f control with simple speed sensor-less vector, speed sensor-less vector control, control with speed sensor vector
	Output frequency control range	0 Hz to 72 Hz (option: up to 120 Hz)
	Output frequency accuracy	Relative highest frequency $\pm 0.5\%$ (at analog frequency reference input)
	Output frequency resolution	0.005%
	Acceleration and deceleration time	0.1 to 5500 s
	Overload capacity	110% 60 s (made-to-order possible tailored to customer's needs)
	Main control functions	Current limit, resonance point automatic frequency hopping, deceleration overvoltage avoidance, frequency stall control, instantaneous power failure restart, etc. Bypass functions (option)
	Protective functions	Overcurrent, main circuit fuse blown, overvoltage, undervoltage, CPU abnormal, cooling fan stopped, etc.
	Communication functions (option)	T-LINK, Profibus-DP, Modbus
Structure	Panel structure	Steel self-closing panel
	Protection grade	IP20 (option available up to IP42)
	Cooling system	Forced air cooling by fan at panel top
	Paint color	RAL7032 (orange peel finish)
Ambient conditions	Ambient temperature	0 to +40°C (storage temperature: -10 to +60°C)
	Humidity	Less than 90% RH (non-condensing), RH up to 95% option available
	Altitude	Max. 1000 m above sea level (high altitude specification option also available)
	Vibration	4.9 m/s ² or less (10 to 50 Hz)
	Installation location	Indoor general environment, with no corrosive gas, dust, flammable, explosive gas
Applicable standards		IEC, GB, DL

Standard connection diagram

Standard connection diagram

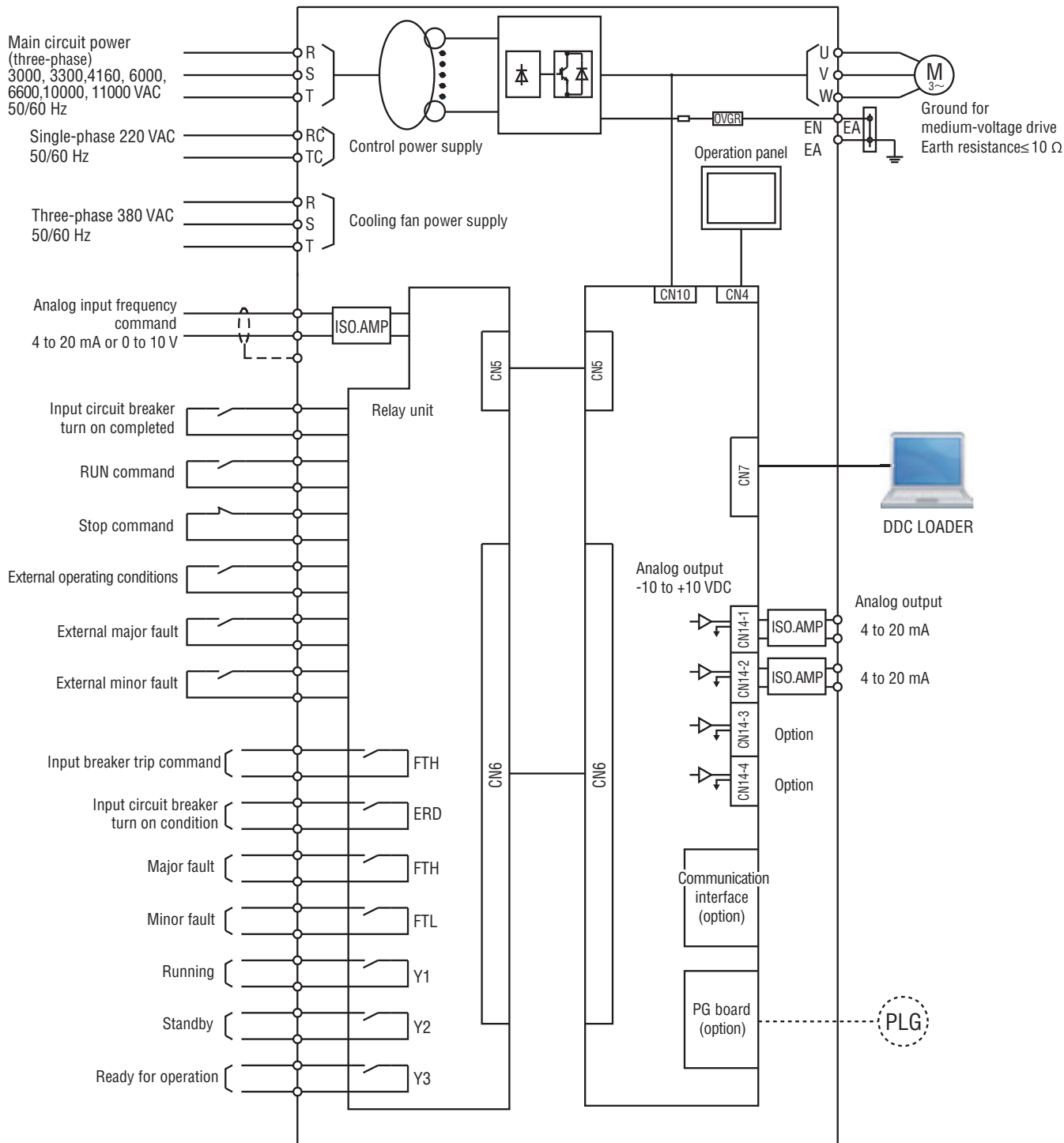



Standard interface

Input side		
Main circuit power supply	Three-phase 3000/3300/4160/6000/6600/10000/11000 VAC, 50/60 Hz	
Control power supply	Single-phase 200/220 V, 50/60 Hz (10 kV: single-phase 220 V, 50 Hz)	
Fan power supply	Three-phase 200/220 V, 50/60 Hz (10 kV: three-phase 380 V, 50 Hz)	
Frequency setting (*)	0 to 10 V / 0 to 100%	Input impedance 1 MΩ
	or 4 to 20 mA / 0 to 100%	Input impedance 250 Ω
Run command	Opening for run ("a" contact)	Dry contact
Stop command	Opening for stop ("b" contact)	
External operating conditions	Closure when ready ("a" contact)	
Input circuit breaker turn on completed	Closure when closed ("a" contact)	

(*): 1 point as standard, maximum 2 points as option.

Output side		
Ready for operation	Closure when ready ("a" contact)	Dry contact (contact capacity: 250 VAC, 2 A or 30 VDC, 3 A)
Running	Closure under operation ("a" contact)	
Major fault	Closure at major fault ("a" contact)	
Minor fault	Closure at minor fault ("a" contact)	
Input circuit breaker turn on condition	Closure when electrical condition ready ("a" contact)	
Input breaker trip command	Closure in major fault ("a" contact)	
Analog signal (option) (*)	0 to 10 V	Load resistance 10 kΩ or more
	4 to 20 mA	Load resistance 750 Ω or less

(*): The analog output signal is selectable (output current, output voltage, output frequency, and others). 2 points as standard, maximum 4 points as option.

Format Description

FRN46 – 6 F A – 60 5 60 – 1000 A

Basic format

Code	Product category
FRN46-6	FRENIC4600FM6e

Control method

Code	Control method
F	Variable torque (VT), simple speed sensor-less vector control
S	Constant torque (CT), speed sensor-less vector control
V	Constant torque (CT), with speed sensor vector control

Input voltage

Code	Input voltage
30	3.0 kV
33	3.3 kV
42	4.16 kV
60	6.0 kV
66	6.6 kV
X0	10 kV
X1	11 kV

Input frequency

Code	Input frequency
5	50 Hz
6	60 Hz

Auxiliary power

Code	Auxiliary power
A	Control power supply: single-phase 220 VAC Fan power supply: three-phase 380 VAC
Z	Other

Output capacity

Code	Output capacity
0450 to 0920	450 to 920 kVA
1000 to 9500	1000 to 9500 kVA
10000 to 18300	10000 to 18300 kVA

* For details, see the reference capacity standard.

Output voltage

Code	Output voltage
30	3.0 kV
33	3.3 kV
42	4.16 kV
60	6.0 kV
66	6.6 kV
X0	10 kV
X1	11 kV

* There are restrictions on the combination of input and output voltages.

Selection of capacity

Selection of standard capacity

Three-phase 3 kV series; Overload capacity: 110% 1 min.

Input voltage [kV]	Rated capacity [kVA]	Rated current [A]	Maximum current ^{*1} (overload) [A]	Full width (transformer panel + converter panel) [mm]	Depth ^{*2} [mm]	Overall height [mm]	Overall height (excluding fan) [mm]	Approximate mass ^{*3} [kg]				
3.0	500	93	102	3000 (1750+1250)	1100	2574	2060	4500				
3.3	550											
3.0	700	130	143					4800				
3.3	740											
3.0	900	178	196					5000				
3.3	1000											
3.0	1200	227	250	3500 (1950+1550)	1300	2557	2160	6250				
3.3	1300											
3.0	1350	266	293					6450				
3.3	1500											
3.0	1600	312	343					6800				
3.3	1750											
3.0	2000	385	423	4200 (2150+2050)	1400	2557	2160	8000				
3.3	2200											
3.0	2250	440	484					8400				
3.3	2500											
3.0	2600	500	550					9600				
3.3	2850											
3.0	3150	635	699	6500 (2200+1900+VCB panel 2400)	1600	3057	2600	11300				
3.3	3600											
3.0	3500	675	743					13500				
3.3	3850											
3.0	4700	914	1006					7500 (2800+2300+VCB panel 2400)	1700	3057	2600	
3.3	5200											
3.0	4950	962	1059									
3.3	5500											

*1: Output current is limited at an output frequency of 25 Hz or less. (70% of the rated current at a frequency of 0.2 Hz)

*2: The required maintenance space in front of the unit is 1500 mm. (Space requirement is common to models of all capacities.)

*3: Approximate mass is for the standard specification, and may vary depending on the use of optional features.

Note: The external dimensions are subject to change.



Three-phase 4 kV series; Overload capacity: 110% 1 min.

Input voltage [kV]	Rated capacity [kVA]	RatRated current [A]	Maximum current ¹ (overload) [A]	Full width (transformer panel + converter panel) [mm]	Depth ² [mm]	Overall height [mm]	Overall height (excluding fan) [mm]	Approximate mass ³ [kg]
4.16	700	97	107	2600	1900	2450	2000	3800
4.16	970	135	148					4400
4.16	1250	178	196					4600
4.16	1650	229	252	4500 (2300+2200)	1400	3050	2400	7600
4.16	1900	266	293					7700
4.16	2250	312	343					7900
4.16	2750	382	420	5400 (2800+2600)	1500			10000
4.16	3200	440	484					10200

*1: Output current is limited at an output frequency of 25 Hz or less. (70% of the rated current at a frequency of 0.2 Hz)
 *2: The required maintenance space in front of the unit is 1500 mm. (Space requirement is common to models of all capacities.)
 *3: Approximate mass is for the standard specification, and may vary depending the use of optional features.
 Note: The external dimensions are subject to change.

Three-phase 6 kV series; Overload capacity: 110% 1 min.

Input voltage [kV]	Rated capacity [kVA]	RaRated current [A]	Maximum current ¹ (overload) [A]	Full width (transformer panel + converter panel) [mm]	Depth ² [mm]	Overall height [mm]	Overall height (excluding fan) [mm]	Approximate mass ³ [kg]																
6.0	450	43	47	3600 (1700+1900)	1200	2557	2160	4200																
6.6	500																							
6.0	510	49	54					3600 (1700+1900)	1200	2557	2160	4300												
6.6	550																							
6.0	550	53	58									3600 (1700+1900)	1200	2557	2160	4400								
6.6	600																							
6.0	610	59	65													3600 (1700+1900)	1200	2557	2160	4500				
6.6	670																							
6.0	700	67	74																	3600 (1700+1900)	1200	2557	2160	4600
6.6	770																							
6.0	770	74	82	3700 (1800+1900)	1200	2557	2160																	4900
6.6	840																							
6.0	880	87	96					3700 (1800+1900)	1200	2557	2160													5500
6.6	1000																							
6.0	1000	93	102									3700 (1800+1900)	1200	2557	2160									5100
6.6	1100																							
6.0	1100	106	116													3800 (1800+2000)	1200	2557	2160					6100
6.6	1200																							
6.0	1200	115	127																	3800 (1800+2000)	1200	2557	2160	6200
6.6	1300																							
6.0	1350	130	143	3800 (1800+2000)	1200	2557	2160																	6300
6.6	1500																							

Selection of capacity

Selection of standard capacity

Input voltage [kV]	Rated capacity [kVA]	RaRated current [A]	Maximum current ^{*1} (overload) [A]	Full width (transformer panel + converter panel) [mm]	Depth ^{*2} [mm]	Overall height [mm]	Overall height (excluding fan) [mm]	Approximate mass ^{*3} [kg]
6.0	1500	144	159	4000 (2000+2000)	1200	2557	2160	6800
6.6	1650							7000
6.0	1700	162	180					7200
6.6	1850							7200
6.0	1850	178	196					7100
6.6	2000							7150
6.0	2000	192	211	7650				
6.6	2200			7750				
6.0	2250	218	240	7900				
6.6	2500			8000				
6.0	2500	241	265	10100				
6.6	2750			10300				
6.0	2750	266	293	11700				
6.6	3000			11800				
6.0	3000	289	318	16500				
6.6	3300			16950				
6.0	3300	312	343	20500				
6.6	3600			21500				
6.0	3700	356	392	23700				
6.6	4000			25500				
6.0	4000	385	424	25000				
6.6	4400			25500				
6.0	4800	462	508	25500				
6.6	5300			25500				
6.0	5200	500	550	25500				
6.6	5700			25500				
6.0	5900	563	619	25500				
6.6	6500			25500				
6.0	6600	635	699	25500				
6.6	7250			25500				
6.0	7000	675	743	25500				
6.6	7700			25500				
6.0	7500	722	794	25500				
6.6	8300			25500				
6.0	8360	803	883	25500				
6.6	9200			25500				
6.0	9400	900	990	25500				
6.6	10000			25500				
6.0	10000	962	1058	25500				
6.6	11000			25500				

*1: Output current is limited at an output frequency of 25 Hz or less. (70% of the rated current at a frequency of 0.2 Hz)

*2: The required maintenance space in front of the unit is 1500 mm. (Space requirement is common to models of all capacities.)

*3: Approximate mass is for the standard specification, and may vary depending the use of optional features.

Note: The external dimensions are subject to change.



Three-phase 10 kV series; Overload capacity: 110% 1 min.

Input voltage [kV]	Rated capacity [kVA]	Rated current [A]	Maximum current ^{*1} (overload) [A]	Full width (transformer panel + converter panel) [mm]	Depth ^{*2} [mm]	Overall height [mm]	Overall height (excluding fan) [mm]	Approximate mass ^{*3} [kg]		
10	500	29	32	3400	1700	2460	2100	3700		
10	625	36	40					3900		
10	700	40	44					4000		
10	800	46	51					4100		
10	920	53	58					4200		
10	1000	58	64					4300		
10	1160	67	74					4600		
10	1280	74	81					4700		
10	1350	78	86					4800		
10	1500	87	96					4900		
10	1600	93	102	5000						
10	1700	98	108	5400 (2400+3000)	1300	2783	2253	6000		
10	1850	107	118					6100		
10	2000	115	127					6700		
10	2250	130	143					6800		
10	2500	144	158					6950		
10	2750	159	175					7050		
10	3080	178	196					7150		
10	3350	193	212					9900		
10	3750	217	239	7100 (2900+4200)	1500	3064	2453	11500		
10	4200	242	266					11600		
10	4600	266	293					11800		
10	5000	289	318					11900		
10	5400	312	343	7300 (3100+4200)	1500	3064	2453	13000		
10	5850	338	372	8300 (3100+5200)				13050		
10	6600	381	419					14200		
10	7000	404	444	11400 (2900+2700+5800)				19650		
10	7700	443	487					19850		
10	8000	462	508					20300		
10	8700	500	550					20400		
10	10500	606	667	12500 (2900+2900+5700+1000)				3119	2551	22000
10	11700	675	743							22400
10	13500	779	857	14100 (3200+3200+6700+1000)				1600	3239	2671
10	16500	962	1058		28800					

*1: Output current is limited at an output frequency of 25 Hz or less. (70% of the rated current at a frequency of 0.2 Hz)
 *2: The required maintenance space in front of the unit is 1500 mm. (Space requirement is common to models of all capacities.)
 *3: Approximate mass is for the standard specification, and may vary depending the use of optional features.
 Note: The external dimensions are subject to change.

Selection of capacity

Selection of standard capacity

Three-phase 11 kV series; Overload capacity: 110% 1 min.

Input voltage [kV]	Rated capacity [kVA]	Rated current [A]	Maximum current ¹ (overload) [A]	Full width (transformer panel + converter panel) [mm]	Depth ² [mm]	Overall height [mm]	Overall height (excluding fan) [mm]	Approximate mass ³ [kg]				
11	625	33	36	3700	1700	2460	2100	4100				
11	700	37	40					4300				
11	800	42	46					4400				
11	920	48	53					4500				
11	1000	52	58					4600				
11	1150	60	66					4700				
11	1250	67	74					5100				
11	1350	71	78					5200				
11	1500	79	87					5300				
11	1600	84	92					5400				
11	1750	93	102	6600 (2800+3800)	1500	2830	2300	8100				
11	1850	97	107					8200				
11	2000	105	115					9000				
11	2250	118	130					9200				
11	2500	130	143					9300				
11	2750	144	159					9400				
11	3100	163	179					9600				
11	3400	178	196					8100 (3100+5000)	1500	3111	2500	11400
11	3750	197	217									13100
11	4200	220	242									13300
11	4600	241	266	13500								
11	5000	266	293	13300								
11	5400	283	312	14400								
11	6000	312	343	21800								
11	6600	346	381	22000								
11	7000	367	404	11800 (2900+2900+6000)	1600	3086	2600					22300
11	7700	404	445									22500
11	8400	440	484	13000 (3100+3100+6800)	1700	3239	2600	23100				
11	8700	457	502					23200				
11	9500	500	550	15700 (3700+3700+6100+ VCB panel 1100+CTR panel 1100)	1600	3086	2600	30500				
11	11500	604	664					16700 (3700+3700+7100+ VCB panel 1100+CTR panel 1100)	1700	3239	2600	36900
11	12800	675	743	16700 (3700+3700+7100+ VCB panel 1100+CTR panel 1100)	1700	3239	2600					36900
11	15000	787	866					36900				
11	18300	962	1058									

*1: Output current is limited at an output frequency of 25 Hz or less. (70% of the rated current at a frequency of 0.2 Hz)

*2: The required maintenance space in front of the unit is 1500 mm. (Space requirement is common to models of all capacities.)

*3: Approximate mass is for the standard specification, and may vary depending the use of optional features.

Note: The external dimensions are subject to change.

FRENIC4600FM6e inverter operation promises substantial energy saving and CO₂ reduction.

In air-conditioning or pumping facilities, fans or pumps typically run at a constant speed even when the load (liquid flow) is light. Adjustable speed control according to the load (air or liquid flow) through inverter operation greatly reduces energy consumption and maintains the maximum possible motor efficiency even at low-speed operation.

Liquid flow and power characteristics

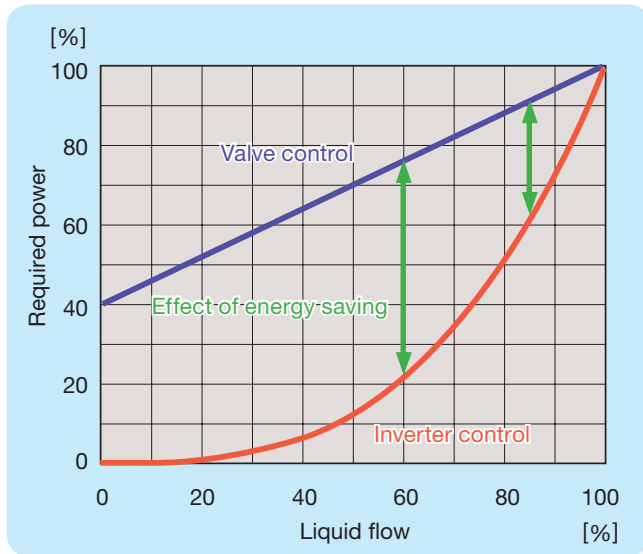

Principle of energy conservation

This can be seen with the principle of fluid dynamics.

$$\frac{Q_1}{Q_2} = \frac{N_1}{N_2}, \frac{H_1}{H_2} = \left(\frac{N_1}{N_2}\right)^2, \frac{P_A}{P_C} = \left(\frac{N_1}{N_2}\right)^3$$

In the equation:

N—rotational speed of the motor

Q—flow

H—pressure

P—shaft output

In the above equation, the flow rate of the load and rotational speed of the motor; the pressure of the load and the square of the rotational speed of the motor; and the output of the load and the cube of the rotational speed of the motor, all have a directly proportional relationship.

Example of usage and effects

When a constant speed electric motor that controls a valve (damper) is operated at a variable speed by the inverter, the energy-saving effects (cost savings) on electric power charges will be as follows.

Example conditions for calculation

Motor output:

1,000 kW, for annual operation time 4,000 hours

Operation pattern:

85% flow for 1/2 of overall time (2,000 hours)

60% flow for the remaining half (2,000 hours)

During constant speed operation of motor

At 85% load of liquid flow (Q)

Required power = 91% x 1,000 kW = 910 kW

At 60% load of liquid flow (Q)

Required power = 76 x 1,000 kW = 760 kW

Annual power consumption

910 kW x 2,000 h + 760 kW x 2,000 h = 3,340,000 kWh

During inverter operation (variable speed operation by the inverter)

At 85% load of liquid flow (Q)

Required power = 61% x 1,000 kW = 610 kW

At 60% load of liquid flow (Q)

Required power = 22% x 1,000 kW = 220 kW

Annual power consumption

610 kW x 2,000 h + 220 kW x 2,000 h = 1,660,000 kWh

Annual energy saving effect

3,340,000 - 1,660,000 = 1,680,000 kWh

If 1 kWh = 0.8 yuan, the electricity bill for the year will be 1.344 million yuan (RMB).

CO₂ reduction = 635,040kg

The abundant variation of products in this series can meet a variety of needs.

Application	Series	Features	Output voltage [V]	Capacity range [kVA]			
				10	100	1000	10000
For plant	FRENIC 4000VM5	Vector controlled inverter for plants • High-performance vector control system for quick response, high-accuracy and wide range of speed control. • The DC-link system allows highly efficient plant operation.	400				5400
	FRENIC 4000FM5	V/f controlled inverter for plants • Frequency of fan, pump and group-driven motors can be controlled accurately. • The DC-link system allows highly efficient plant operation.	400				900
	FRENIC 4400VM6	Large-capacity vector controlled inverter • The capacity of FRENIC4000 series units has been increased due to 3-level control.	800				8400
	FRENIC 4400FM5	Large-capacity V/f controlled inverter • The capacity of FRENIC4000 series units has been increased due to 3-level control.	800				2000
	FRENIC 4800VM6	Medium-voltage, water-cooling, large-capacity and vector controlled inverter • The capacity of FRENIC4000 series units has been increased due to 3-level control. • Downsizing achieved by adopting a water-cooling system	3100				26400
For general industry (medium-voltage)	FRENIC 4600FM5e	Medium-voltage direct-output inverter (for fans and pumps) • Compact design • Variable speed operation of medium-voltage motors saves energy. • Circuit configuration and control are well designed for power supplies and motors.	3000/3300 4160 6000/6600 10000				4750/5200 3300 9500/10500 7950
	FRENIC 4600FM6e	Medium-voltage large-capacity V/f • Vector controlled inverter • Two-level control technology • Applicable for power plants, steel mills, and cement factories • Generator friendly circuit configuration and control design • Power quality is not degraded.	3000/3300 6000/6600 10000 11000				5490 11000 16500 18300
For general industry (low-voltage)	FRENIC-VG FRENIC-VGM	High-performance vector controlled inverter	200 400				90 kW 2400 kW
	FRENIC-MEGA	High-performance V/f controlled inverter	200 400				90 kW 2400 kW
	FRENIC-ECO	V/f controlled inverter for fans and pumps	200 400				110 kW 560 kW

Ordering information

When placing an order or making an inquiry, please state the following.

1. Application of inverter

5. Rotational speed control range:

r/min to r/min

2. Load machine specifications

- Name (Pump, Fan, Blower, Air compressor, Other)
- Load torque characteristics (Square-law speed, Constant torque, Constant output)
- Moment of load inertia after conversion into motor shaft (J): kg•m²
- Overload: %

6. Rotational frequency setting method

- (Analog signal: 4 to 20 mA, 0 to 10 V, Up/down signal, etc.)

3. Input specifications

- Rated voltage: V ± %
- Rated frequency: Hz ± %
- Control power supply: Single-phase, two-wires, 220 V, 50 Hz
- Fan power supply: Three-phase, three-wires, 380 V, 50 Hz

7. Commercial power source bypass circuit (with or without)

4. Drive motor

- Motor specifications (Existing or New installation)
- Rating
Output: kW, No. of poles: ,
Voltage: kV, Frequency: Hz,
Speed: r/min, Rated current: A

8. Ambient conditions

- Install location: Indoor
- Altitude
- Provision of air conditioning
- Limit on carrying-in
- Humidity
- Temperature

 Fuji Electric Co., Ltd.

Gate City Ohsaki, East Tower, 11-2, Osaki 1-chome, Shinagawa-ku, Tokyo 141-0032, Japan
Phone : +81-3-5435-7111

Internet address : www.fujielectric.co.jp

Information in this catalog is subject to change without notice.

2019-3(C2019b/D2016)10FOLS Printed in Japan